

# Estruturas de madeira: conexões e referências projetuais

Maria Augusta Justi Pisani

Faculdade de Arquitetura e Urbanismo da Universidade Presbiteriana  
Mackenzie

Material Didático / setembro de 2021, 102p.





SHEFFIELD WINTER GARDEN - 2003 - Sheffield, Inglaterra  
Madeira utilizada – Pinheiro larício

### 3.1 Superstructure

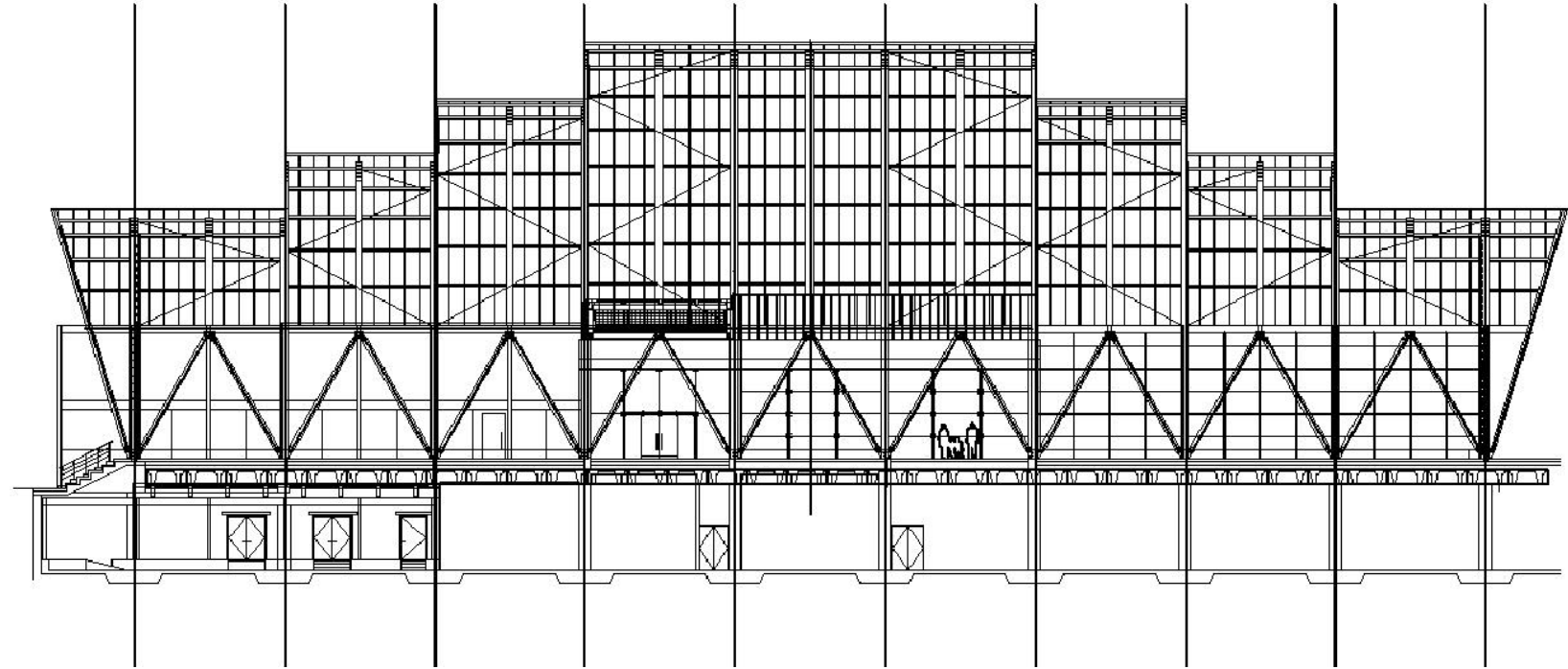
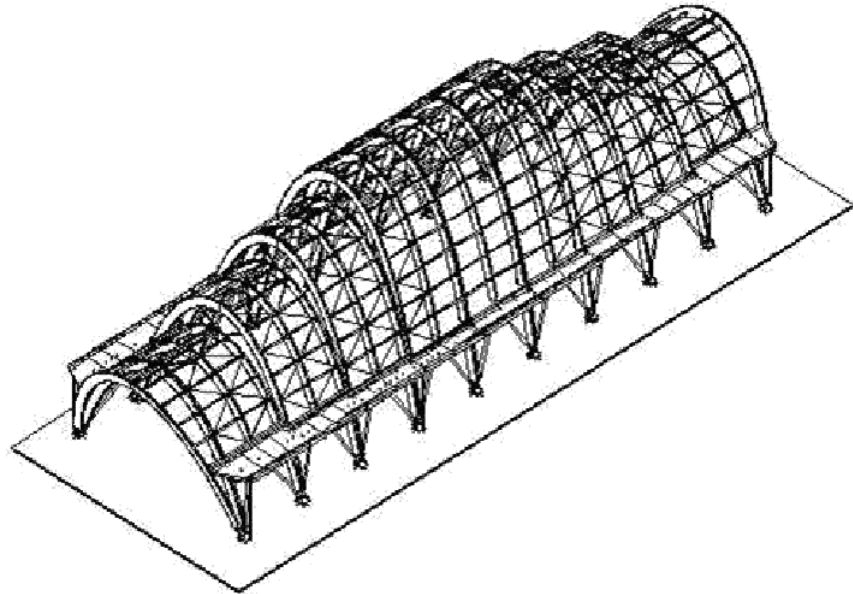
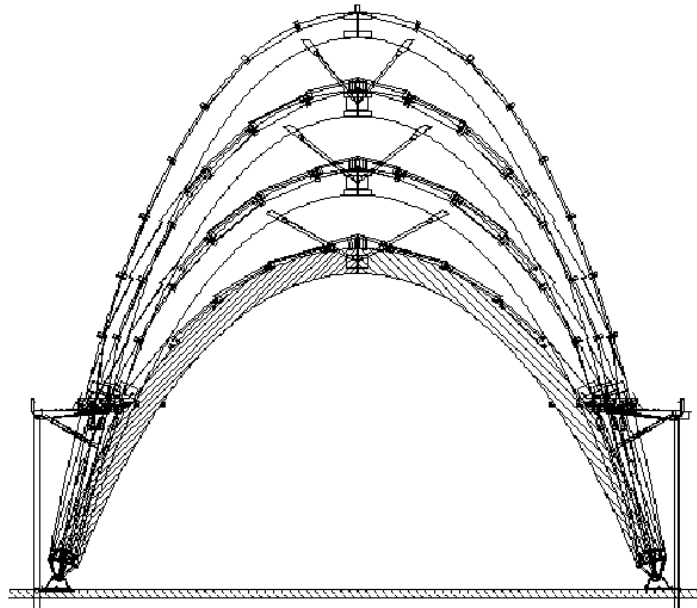

The Winter Gardens, Sheffield, UK

Figure 2 Isometric View



<http://www.prsarchitects.com/projects/arts-civic/sheffield-winter-garden>





Instalação Pública  
EKKO

Arq. Thilo Frank

Ø 20m H 3m

madeira tratada  
fio de aço inoxidável,  
Espaçador metálico  
aço revestido de zinco  
Piso de concreto,  
microfones e sistema de  
som amplificado

Hjallerup,  
Dinamarca  
2012





READER – 2015

Harju Street, Tallinn

Arquitetos:  
Estudantes da  
Academia de Artes  
da  
Estônia

Fonte:

[https://www.archdaily.com.br/br/773761/estudantes-constroem-um-abrigo-ludico-de-madeira-no-centro-de-tallinn-estonia/55f5e3a4e58ecec1f8000038-first-year-architecture-students-design-reader-shelter-in-estonia-photo?next\\_project=no](https://www.archdaily.com.br/br/773761/estudantes-constroem-um-abrigo-ludico-de-madeira-no-centro-de-tallinn-estonia/55f5e3a4e58ecec1f8000038-first-year-architecture-students-design-reader-shelter-in-estonia-photo?next_project=no)









Design Week  
Mexico  
Arquitetos:  
MATERIA  
Ano: 2017  
Chapultepec

MEXICO

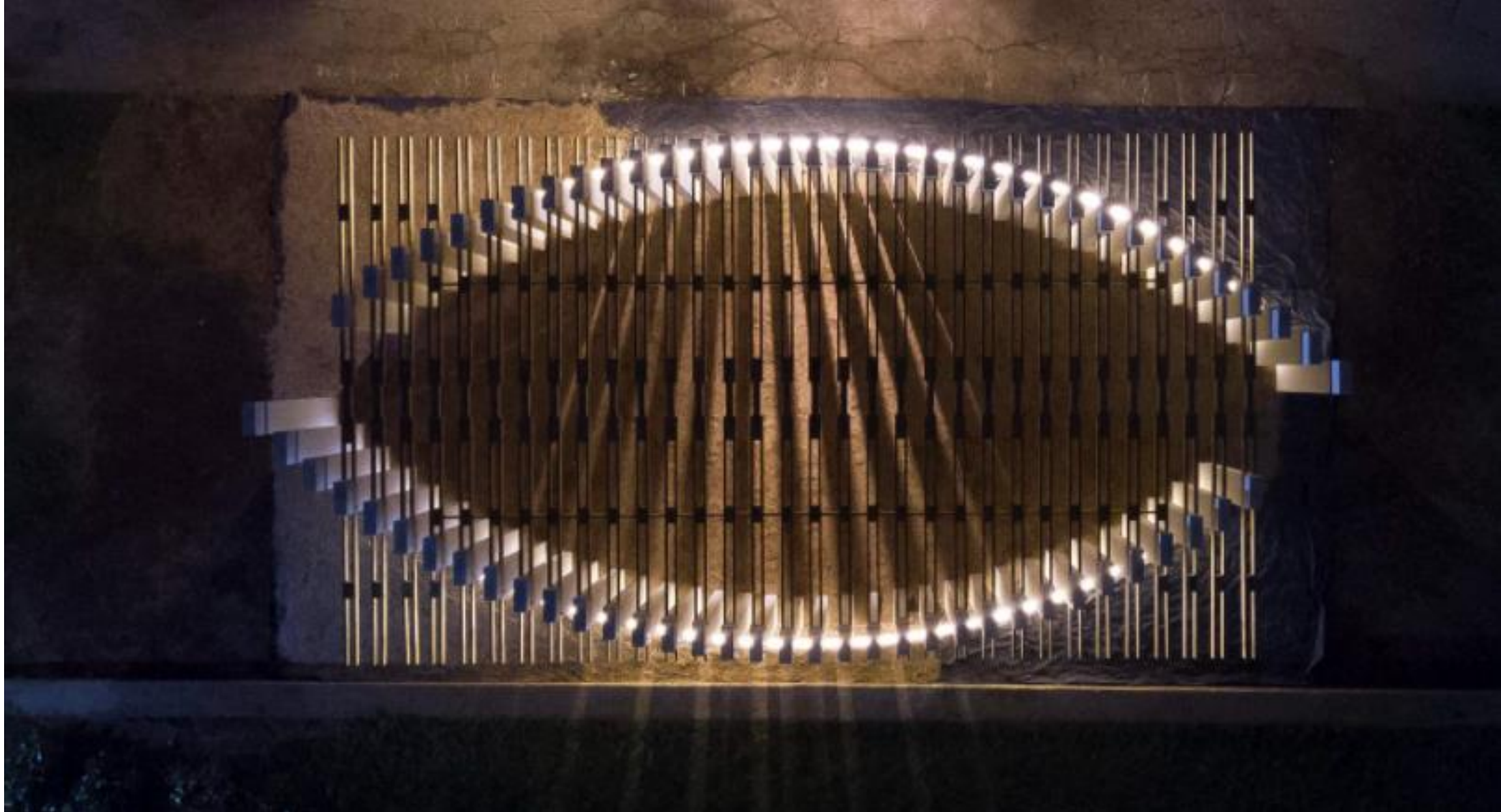

Fonte: [https://www.archdaily.com.br/br/797812/ponte-high-trestle-trail-rdg-planning-and-design/579ed9b8e58ecec079000156-high-trestle-trail-bridge-rdg-planning-and-design-sketch?next\\_project=no](https://www.archdaily.com.br/br/797812/ponte-high-trestle-trail-rdg-planning-and-design/579ed9b8e58ecec079000156-high-trestle-trail-bridge-rdg-planning-and-design-sketch?next_project=no) 11





## Treetop Walk Serralves Parque Serralves

A Fundação de Serralves,  
em colaboração com o  
Fundo Ambiental do  
Estado Português

Arq. Carlos Castanheira  
Com colaboração  
Álvaro Siza

**LOCALIZAÇÃO:** Portugal,  
Porto

**2019**

Fonte:  
<https://espacodearquitetura.com/projetos/treetop-walk-serralves/>

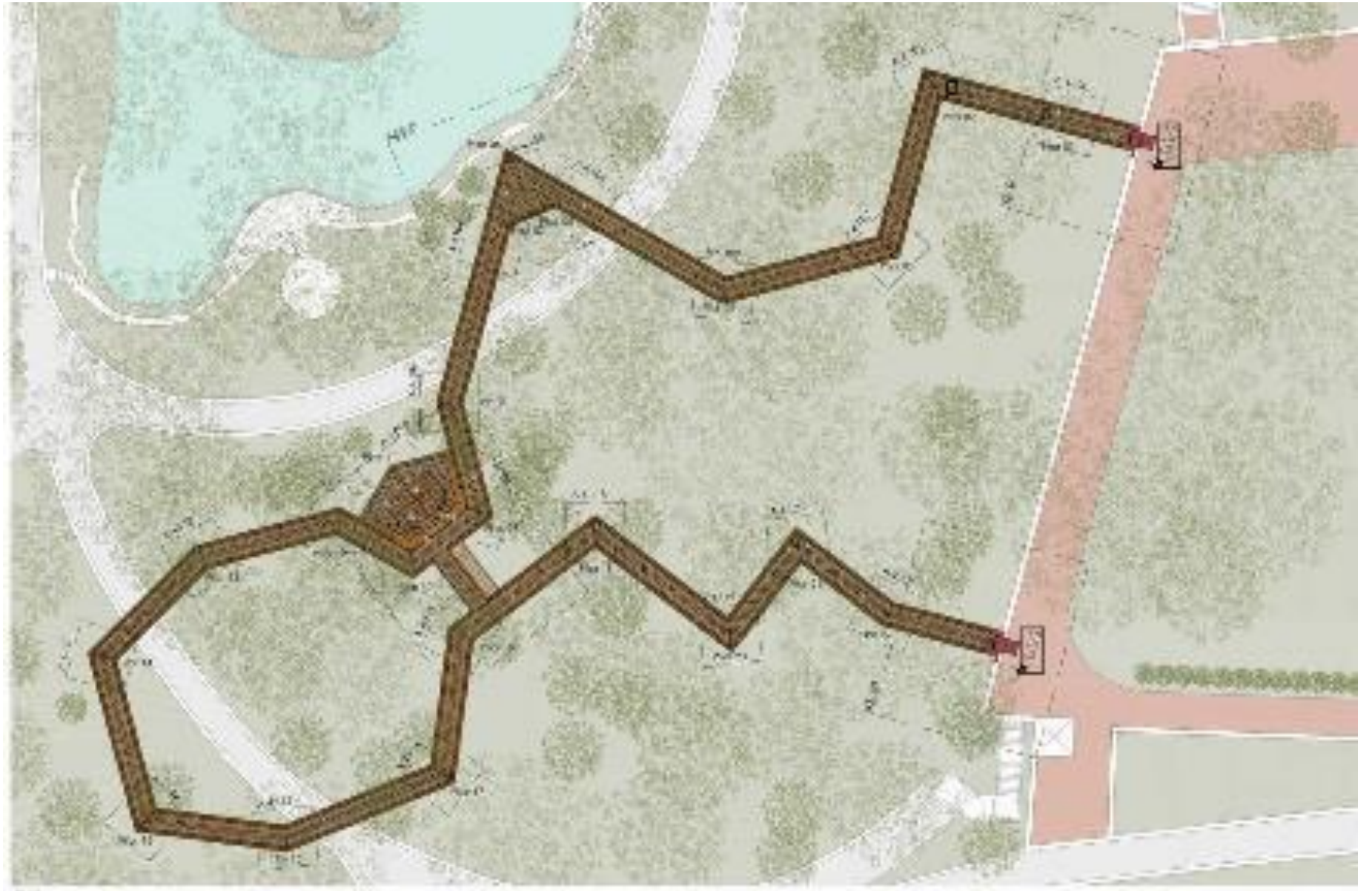











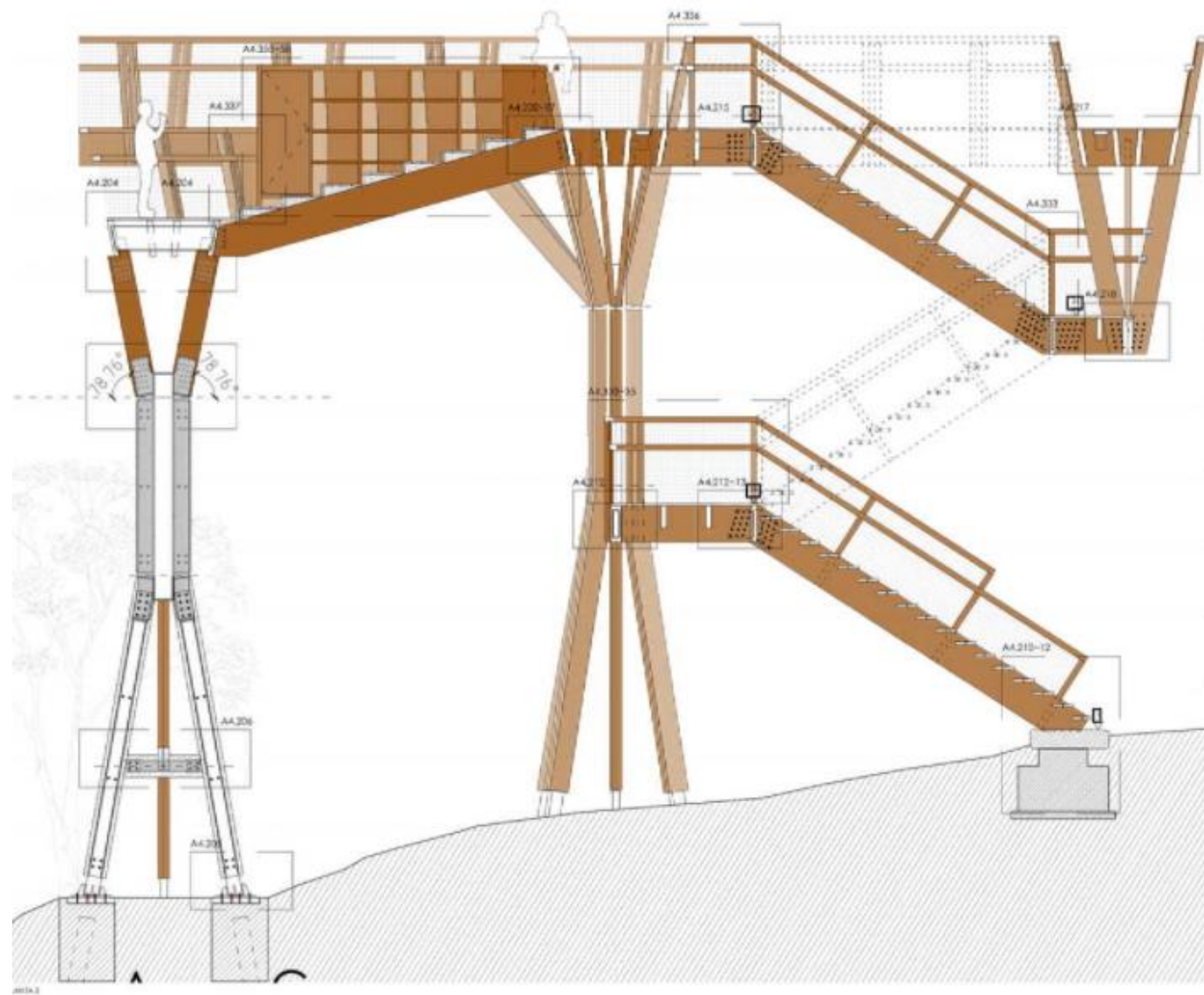
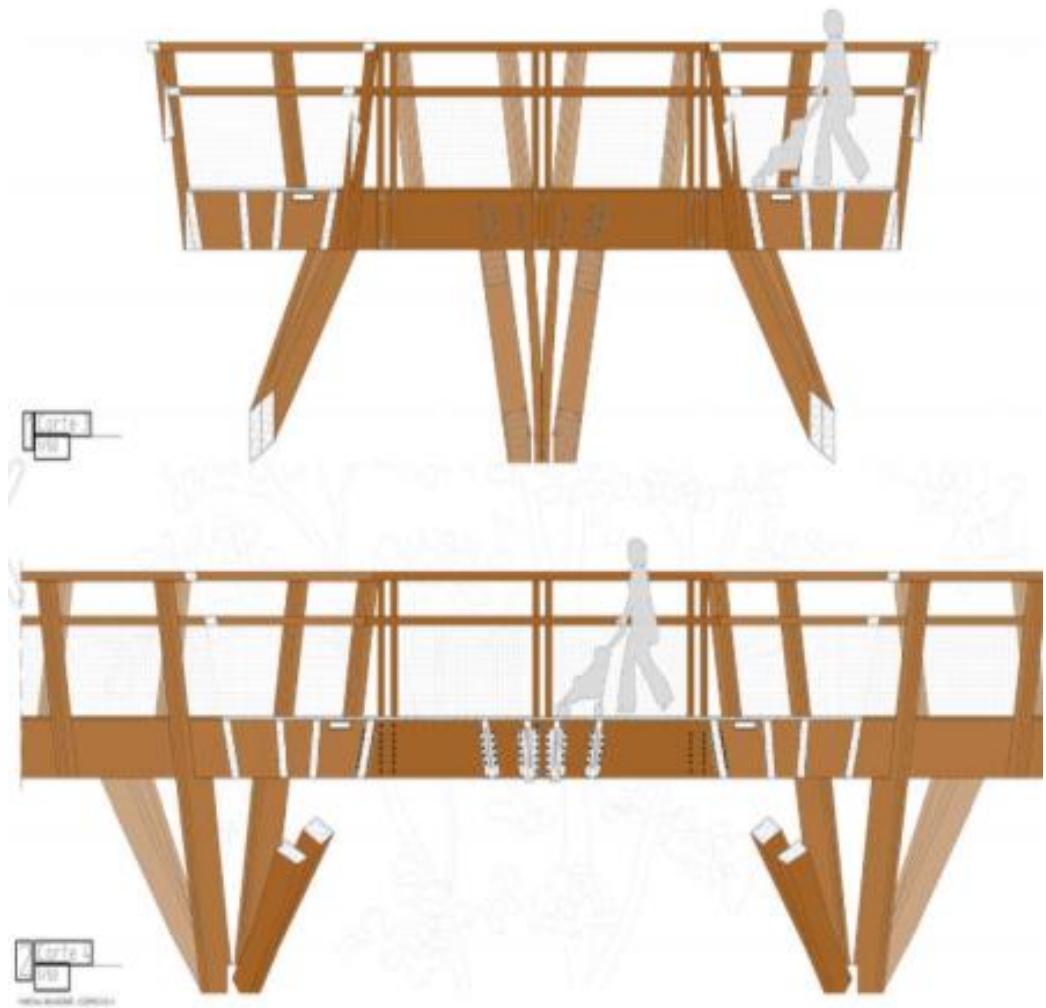

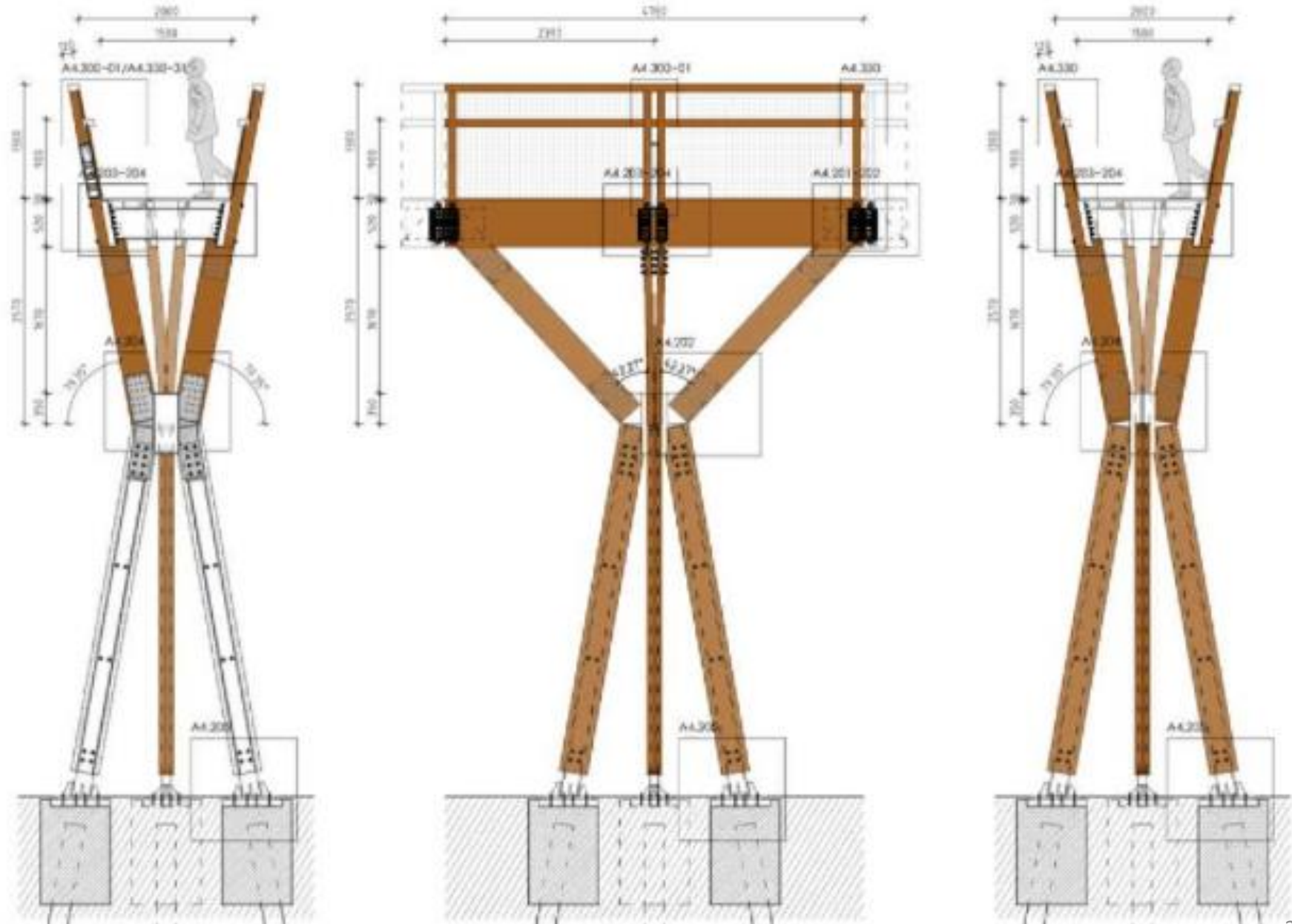

Fonte:  
<https://espacodearquitetura.com/projetos/treetop-walk-serralves/>

Localização: Star  
Saczy, Polônia  
Ano: 2018  
Arquitetos:  
55Architekci

[https://www.archdaily.com.br/br/957835/enclave-natural-bobrowisko-55architekci/601c117df91c81915a000615-the-bobrowisko-nature-enclave-55architekci-photo?next\\_project=no](https://www.archdaily.com.br/br/957835/enclave-natural-bobrowisko-55architekci/601c117df91c81915a000615-the-bobrowisko-nature-enclave-55architekci-photo?next_project=no)





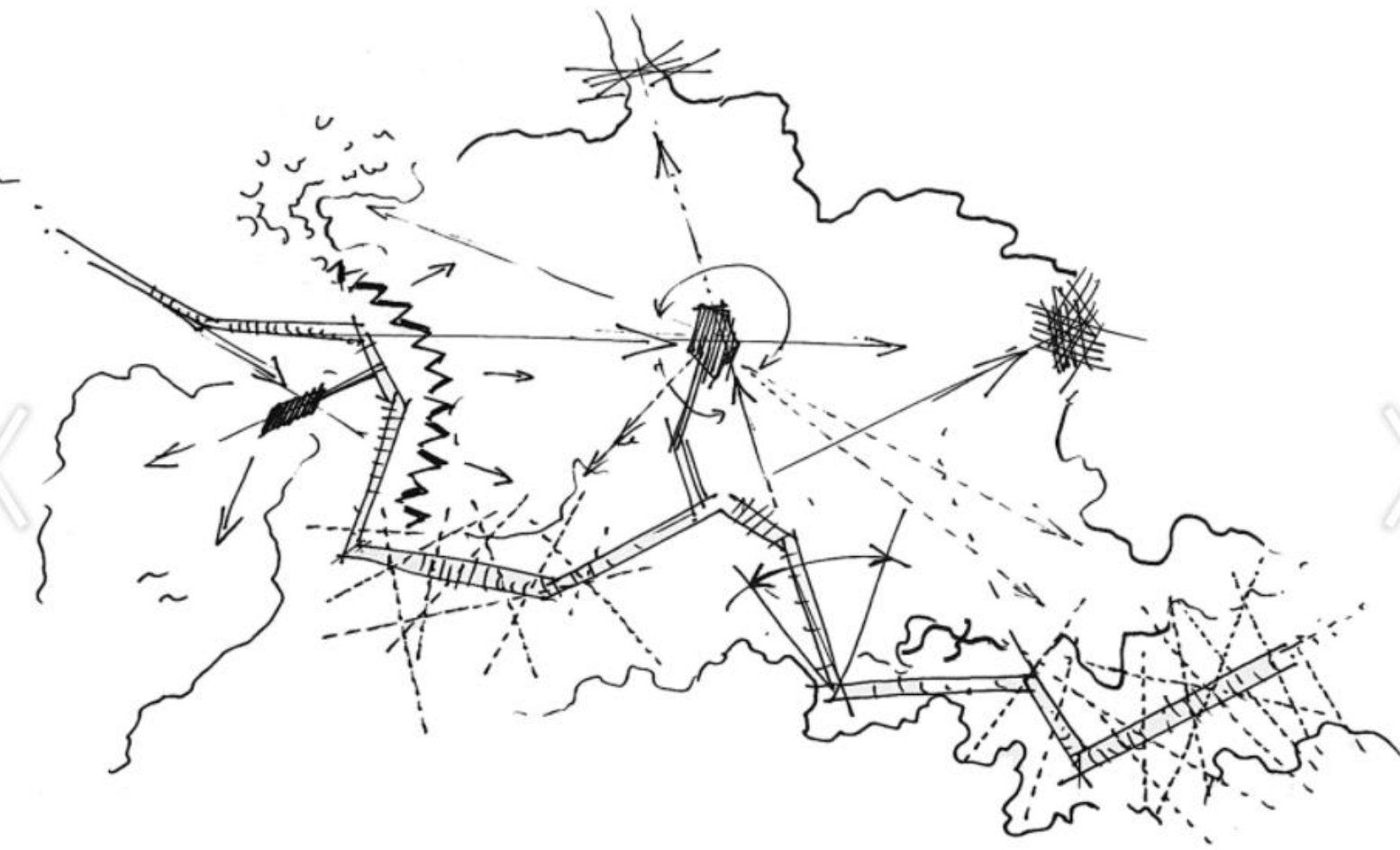
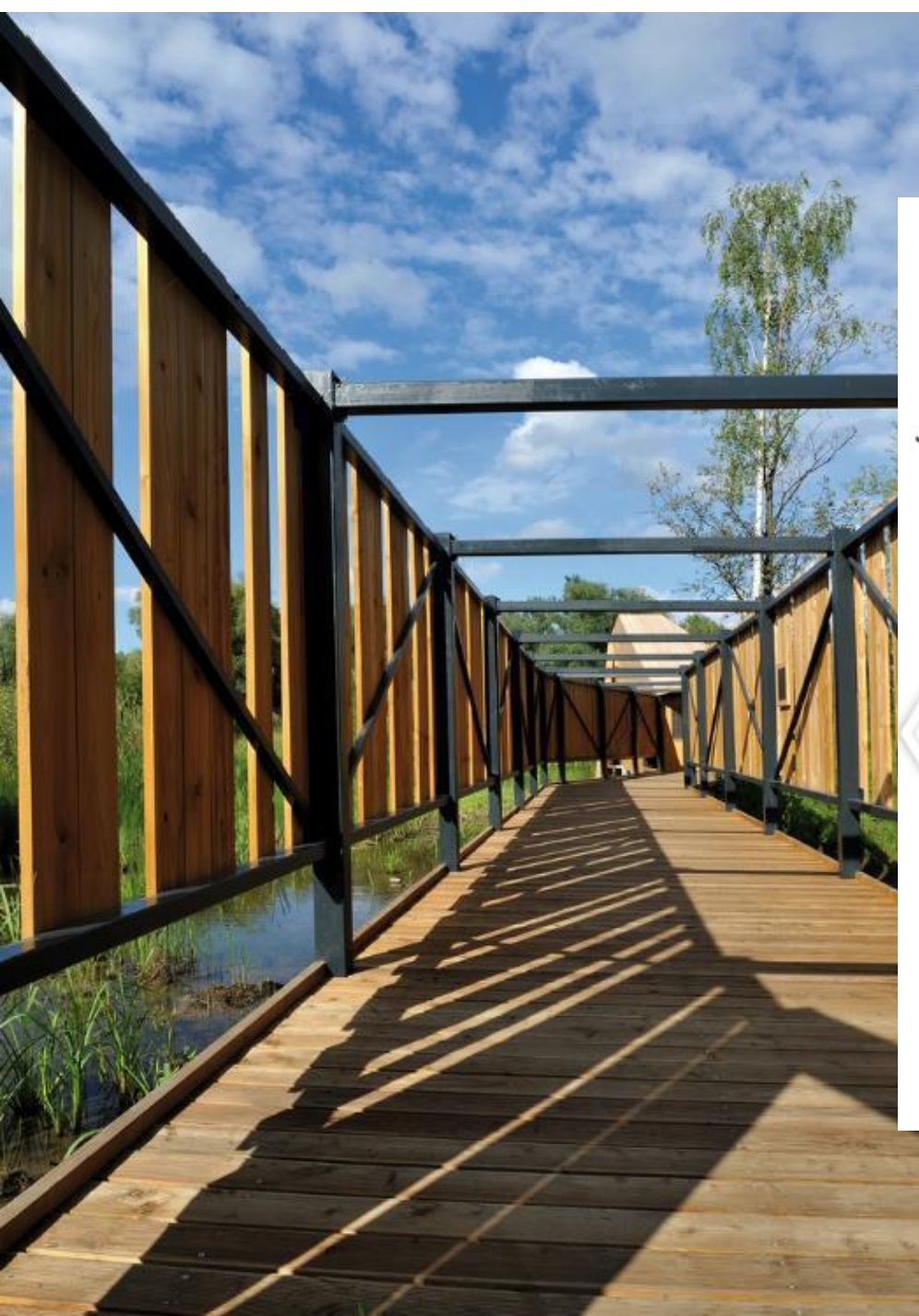







## AUSTRIA CENTER VIENNA – Architecture DI Christian Knechtl 2005-2007

26m larg x 32m comp. e 17 m de altura. estrutura em forma de onda composta por uma malha de madeira laminada colada inclinada com seção transversal de até  $w / h = 20 / 170$  cm.

WOSCHITZ GROUP.

<https://www.woschitzgroup.com/projekte/austria-center-vienna-eingangswelle/>



MADEIRA ENGENHEIRADA. O que é a Madeira Laminada Colada (MLC), 2020  
<https://www.madeiraengenhurada.net.br/post/o-que-%C3%A9-a-madeira-laminada-colada-mlc>

# Meditation Dojo in the Air / 空中禅道場

Awaji, Hyogo, Japan / 兵庫県淡路市、日本

In Progress

[http://www.shigerubanarchitects.com/works/2021\\_meditationdojo/index.html](http://www.shigerubanarchitects.com/works/2021_meditationdojo/index.html)







[http://www.shigerubanarchitects.com/works/2021\\_meditationdojo/index.html](http://www.shigerubanarchitects.com/works/2021_meditationdojo/index.html)

# ASPEN ART MUSEUM – Aspen - Arq. Shiguero Ban, 2007

<https://www.aspenartmuseum.org/about/new-building>





Aspen Art Museum by Shigeru Ban Architects, Aspen, CO

# Centre Pompidou-Metz by Shigeru Ban Architects, Metz, France

<https://architizer.com/blog/inspiration/collections/shigeru-ban-glulam/>





Nine Bridges Country Club / Shigeru Ban Architects  
Yeosu-gun, South Korea

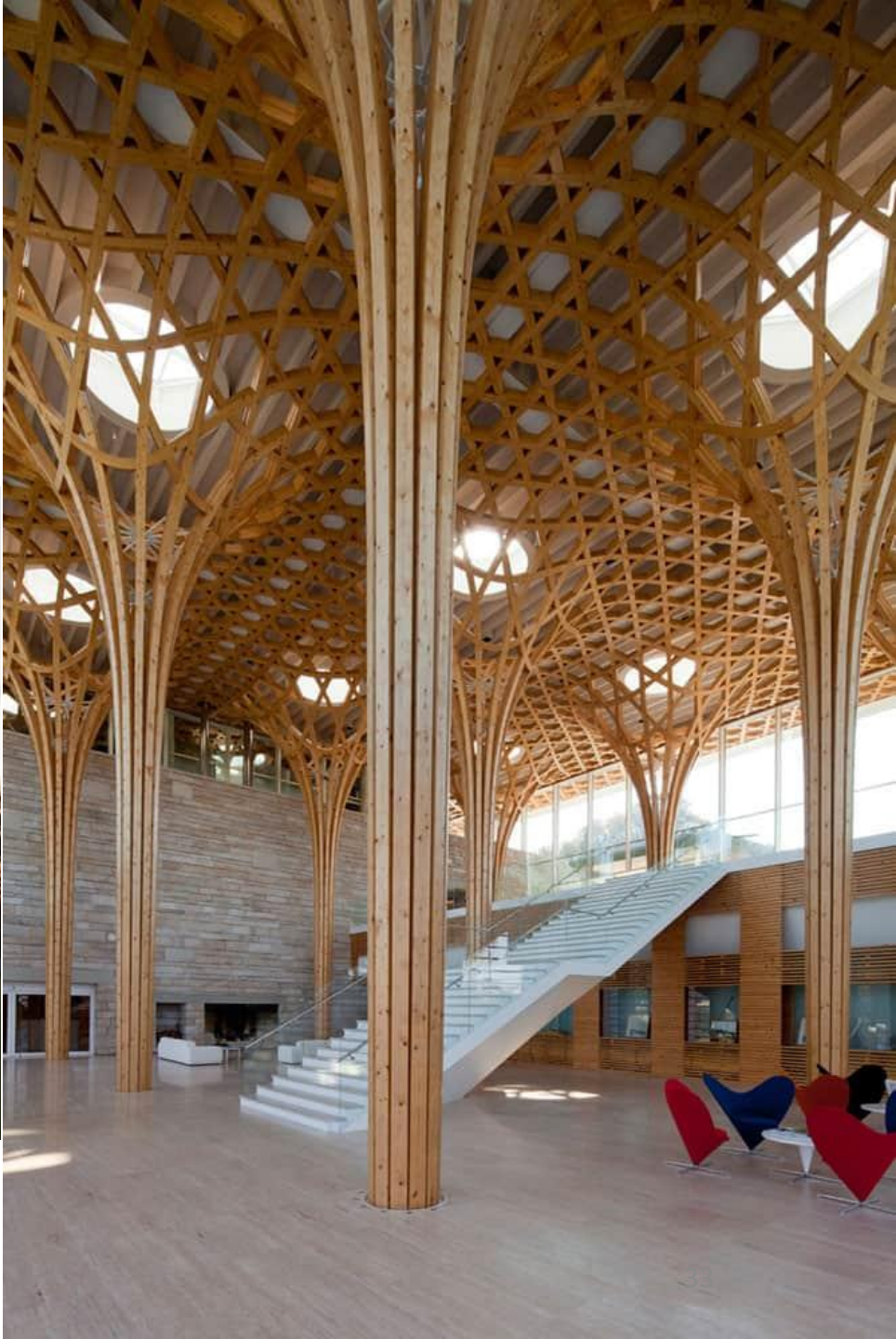



[https://www.archdaily.com.br/br/01-189060/nine-bridges-country-club-slash-shigeru-ban-architects/533258c2c07a806c360000ac-nine-bridges-country-club-shigeru-ban-architects-photo?next\\_project=no](https://www.archdaily.com.br/br/01-189060/nine-bridges-country-club-slash-shigeru-ban-architects/533258c2c07a806c360000ac-nine-bridges-country-club-shigeru-ban-architects-photo?next_project=no)

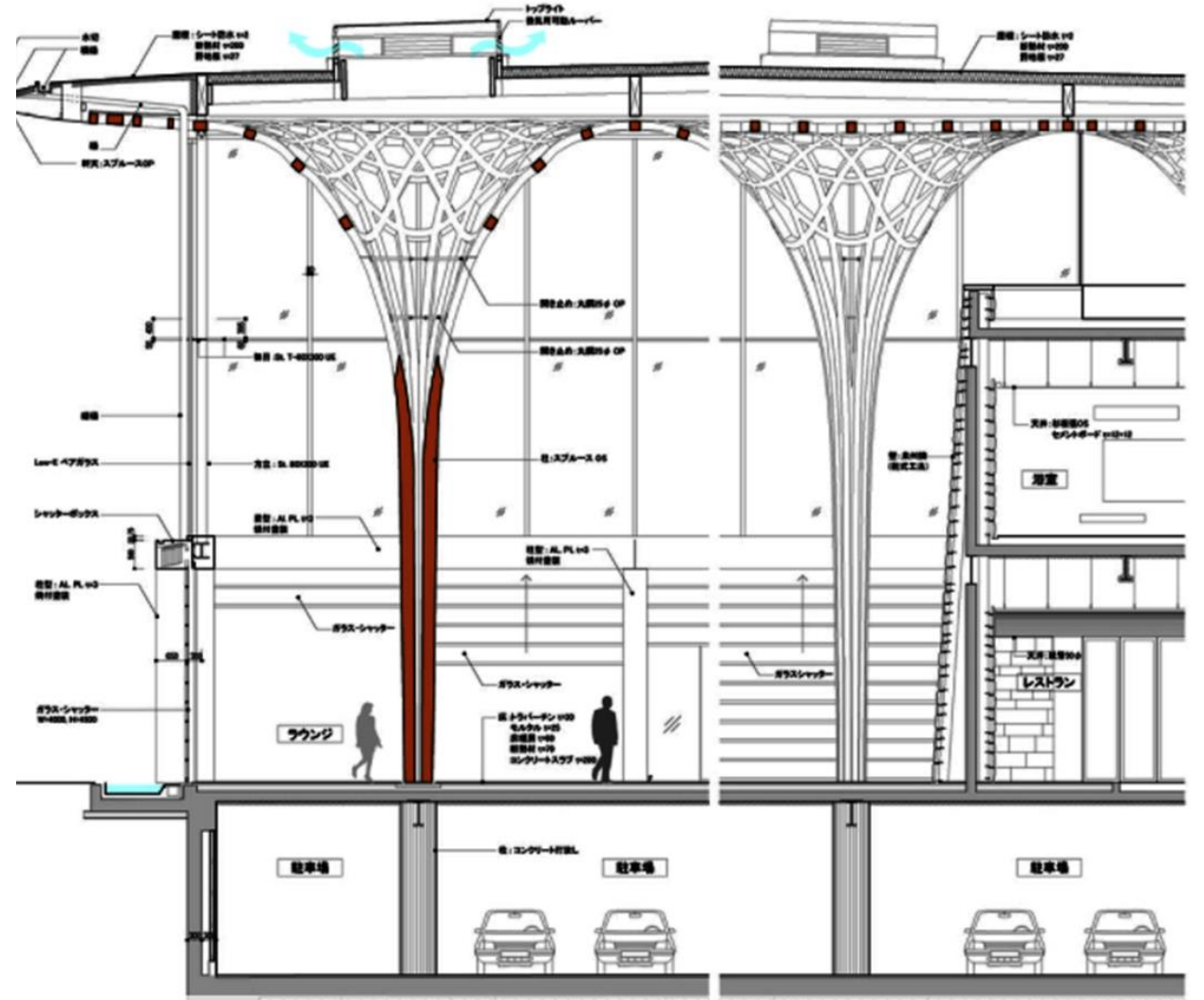
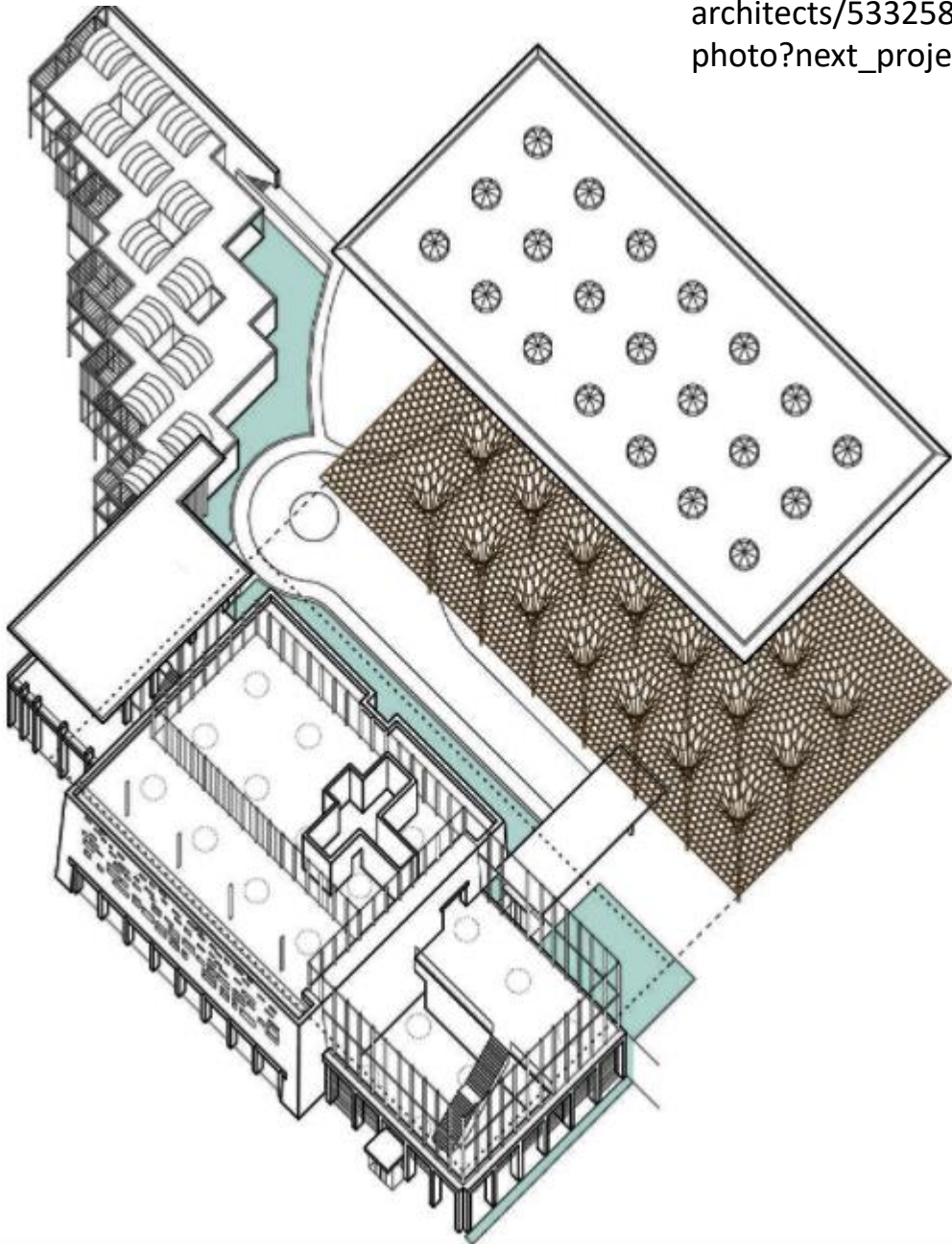



# Future Tree

Robotic Timber meets Digital Concrete  
Esslingen ZH, Switzerland 2018 - 2019

Architect: Gramazio Kohler Research / ETH Zürich

<https://dfab.ch/news/future-tree-robotic-timber-meets-digital-concrete>

<https://dfab.ch/news/future-tree-robotic-timber-meets-digital-concrete>



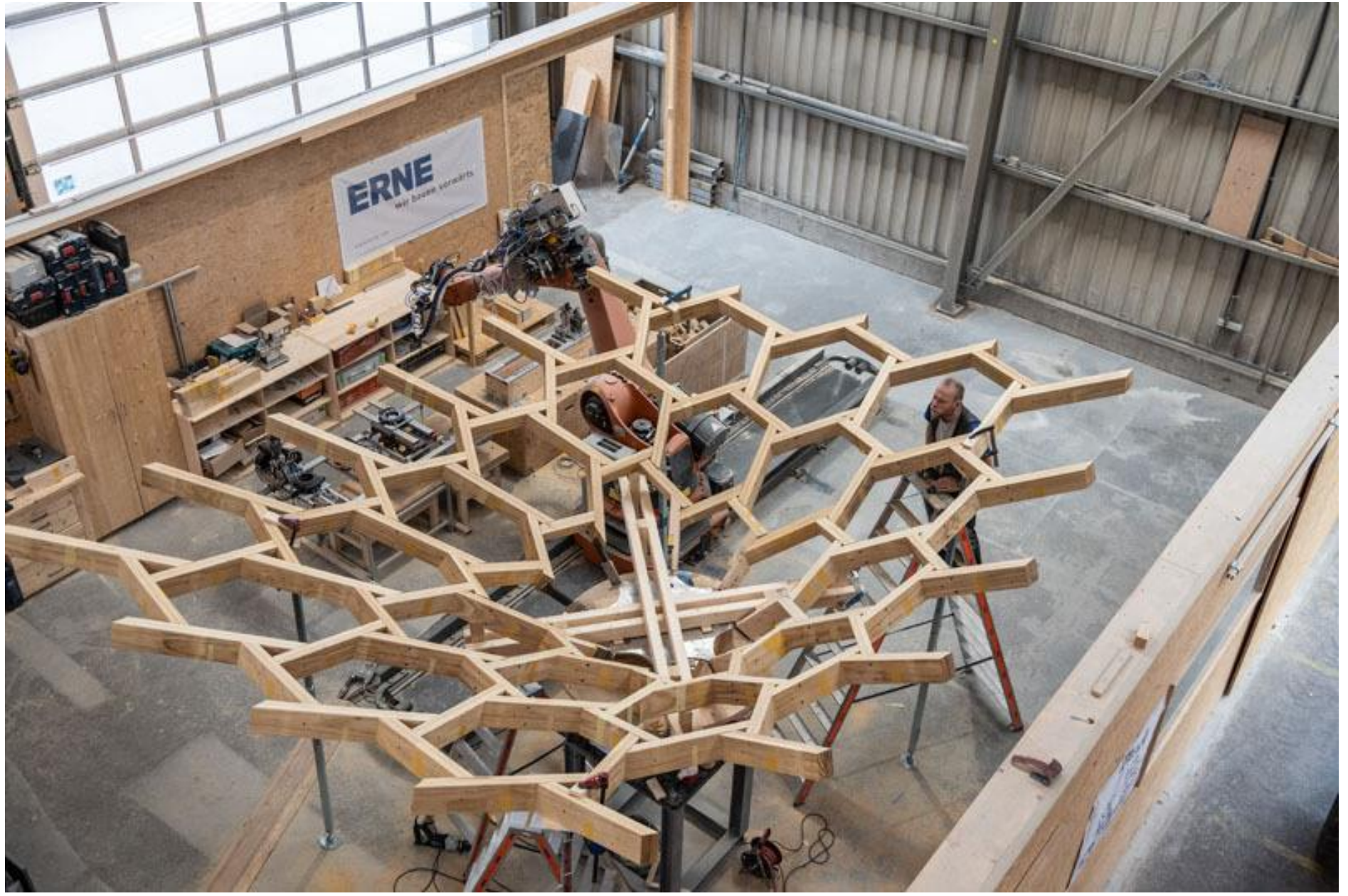

Kenko Kuma - <https://kkaa.co.jp/works/architecture/morinos/>

Cidade de Mino – Província de Gifu – Japão – 2020

Centro Educacional Morinos - 129,04 m<sup>2</sup>.

Pilares em V – com toras de ciprestes – feitas por estudantes de engenharia florestal. A madeira de desbaste dos cedros são empregadas para os montantes da estrutura. As paredes são pintadas/revestidas com o gesso de Gifu. Todos os materiais são locais.













<https://kaa-co.jp>

pavilhão de TLDC Tsumiki do  
mundo Flora Exposition de Taichun  
–China  
Arq. Kenko Kuma



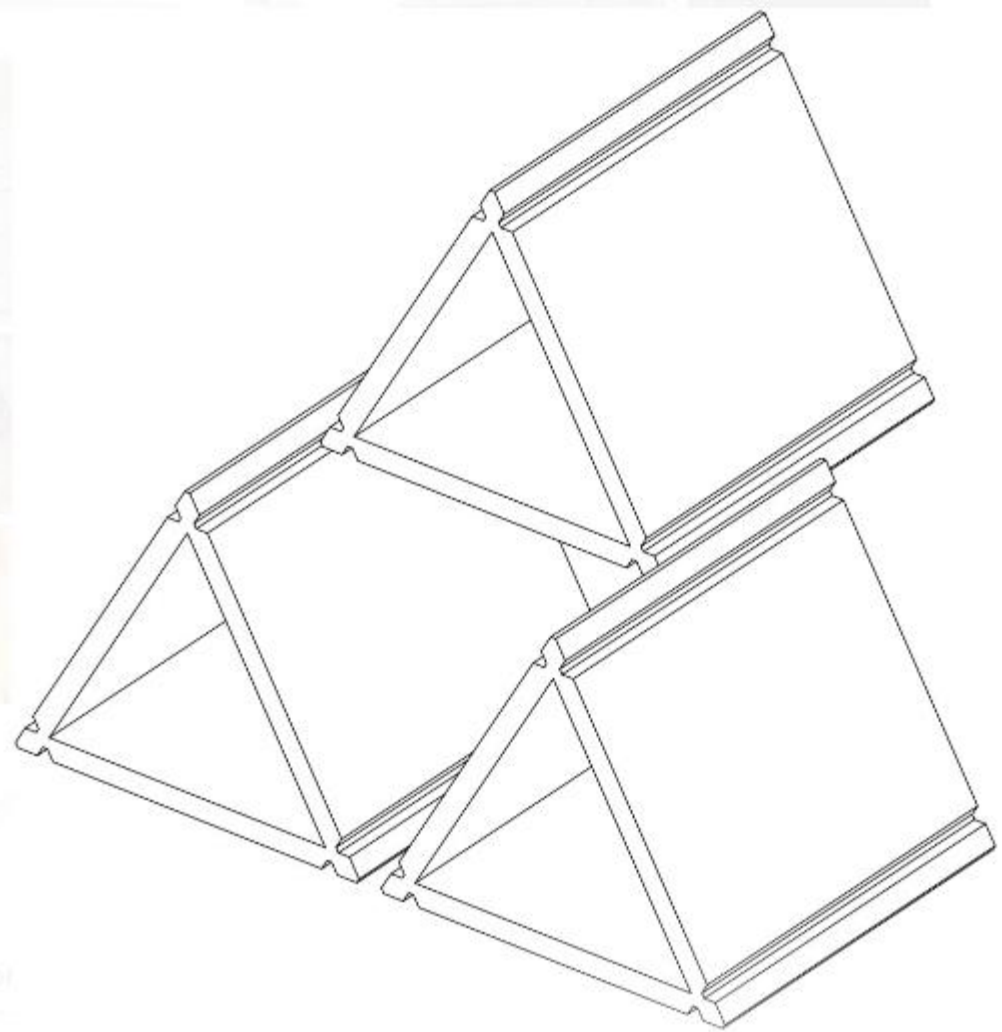

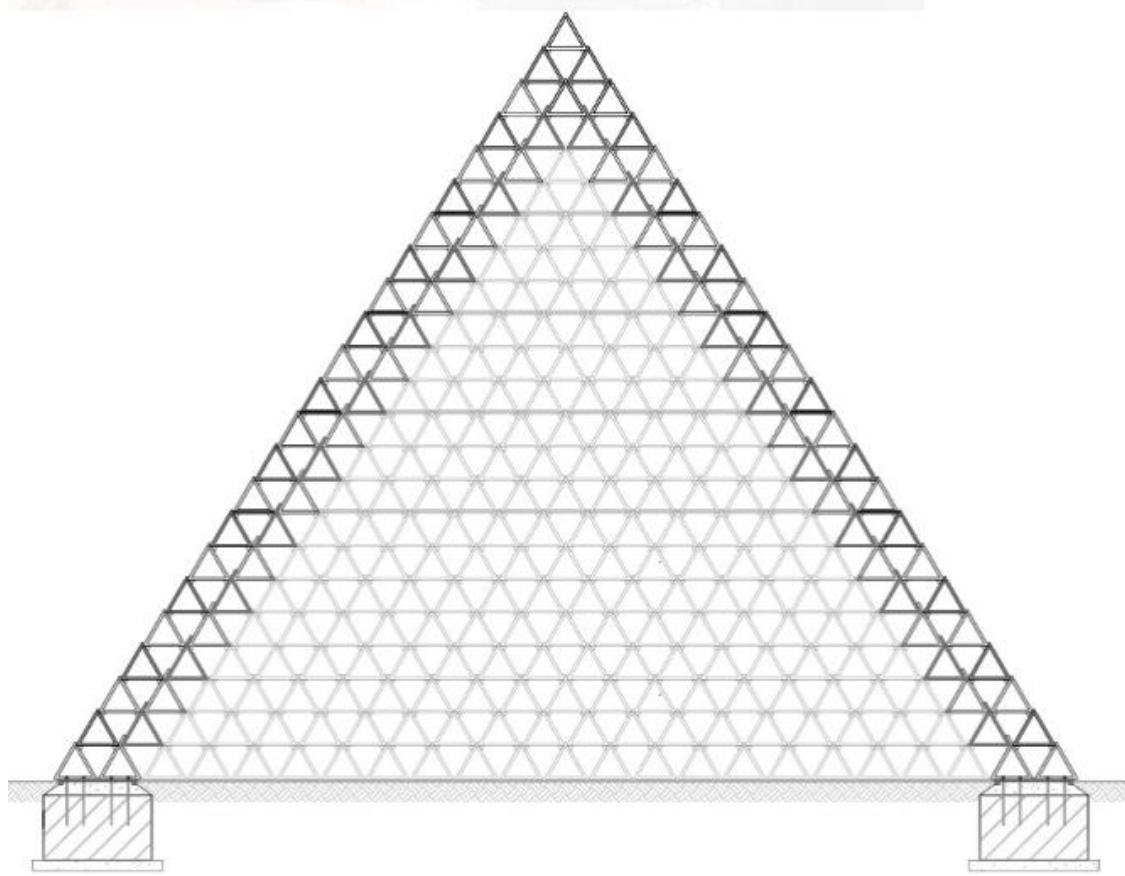

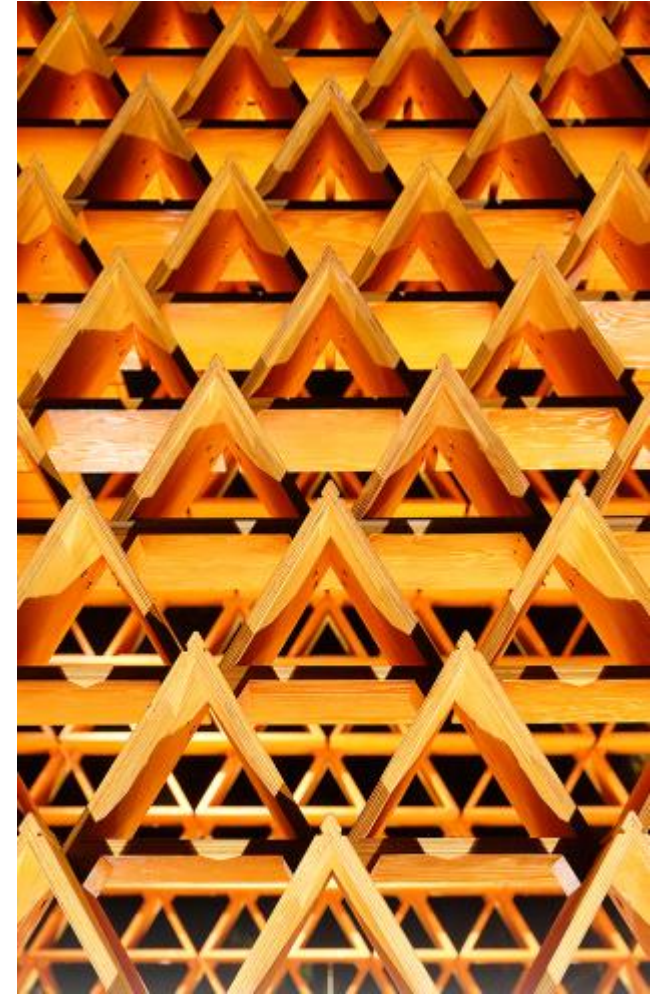

## CONEXÕES EMPREGADAS NAS ESTRUTURAS DE MADEIRA

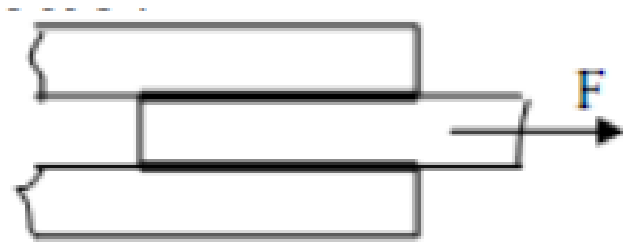

1. Cola

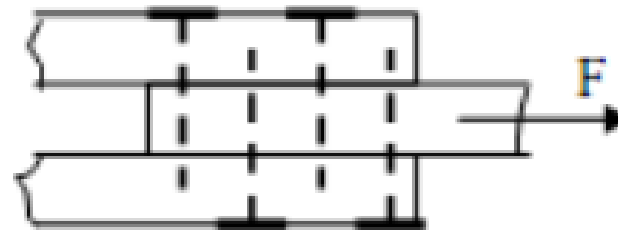

2. Pregos

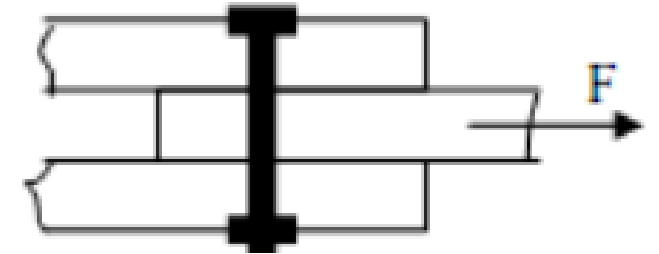

3. Parafuso

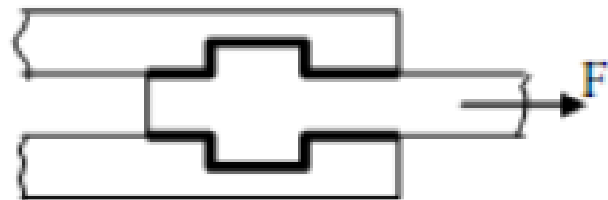

4. Entalhe

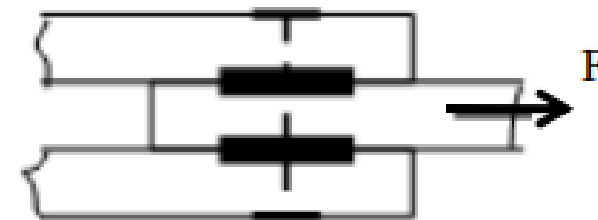

5. Conector



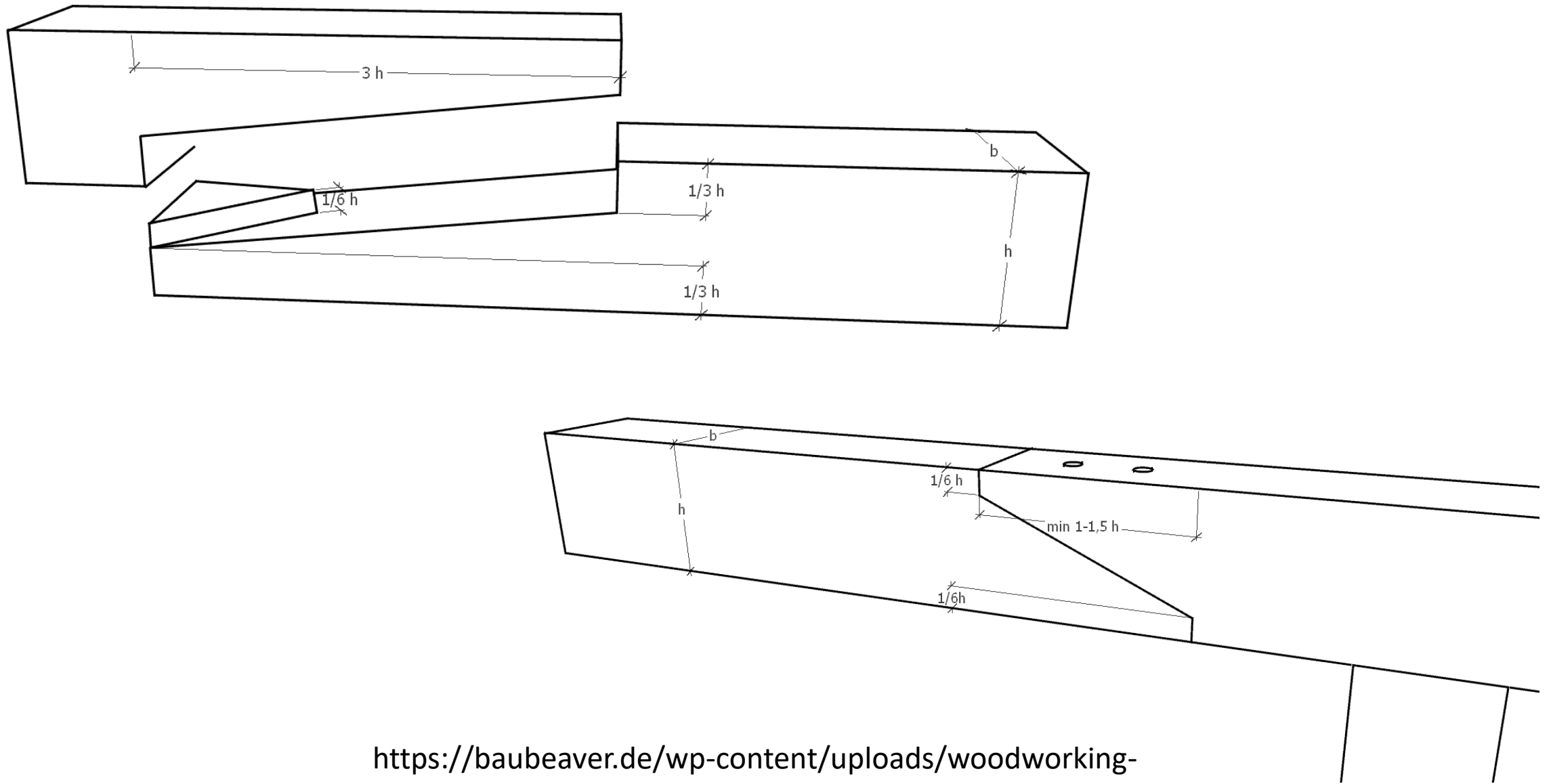

<https://baubeaver.de/wp-content/uploads/woodworking-joints-Oblique-scarf-joint-with-hidden-hook.png>

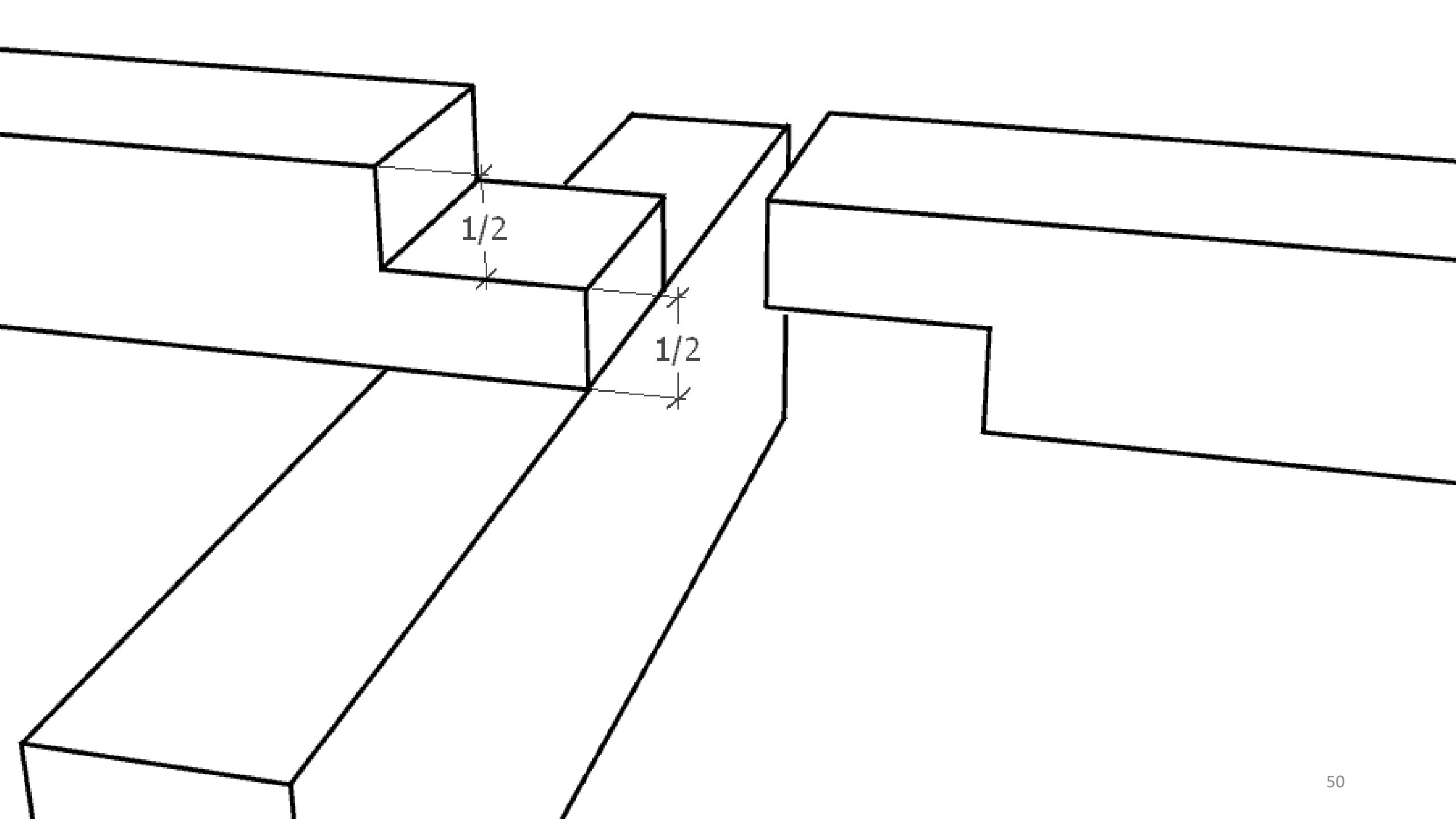

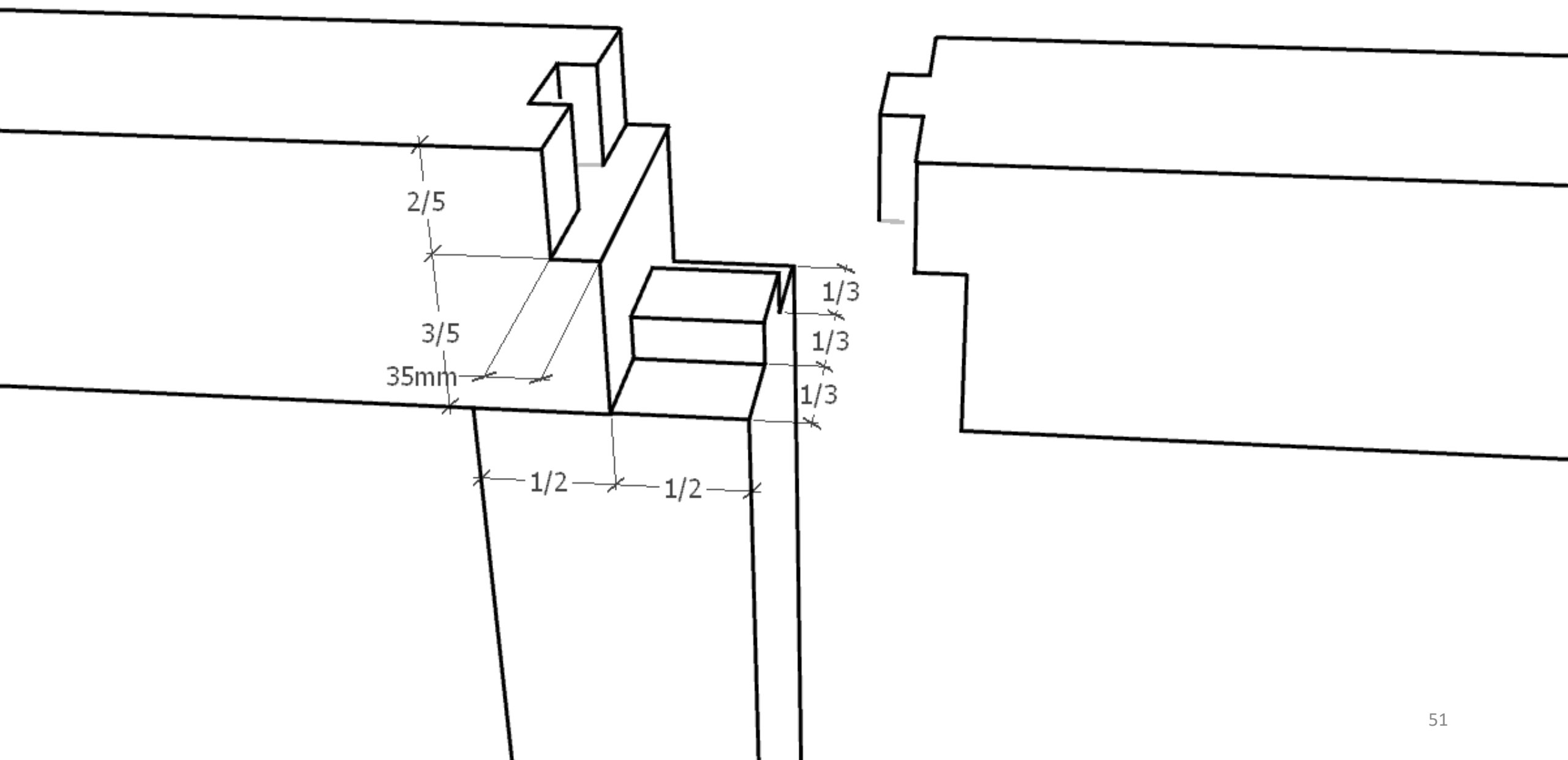

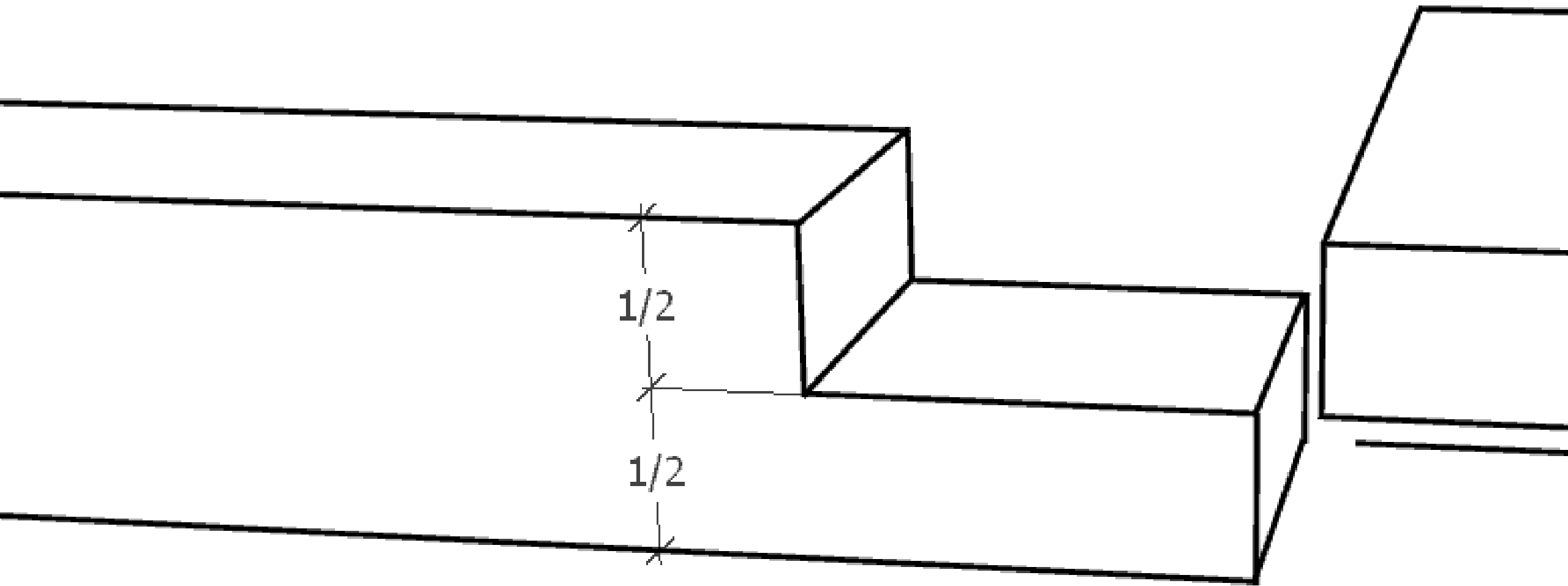

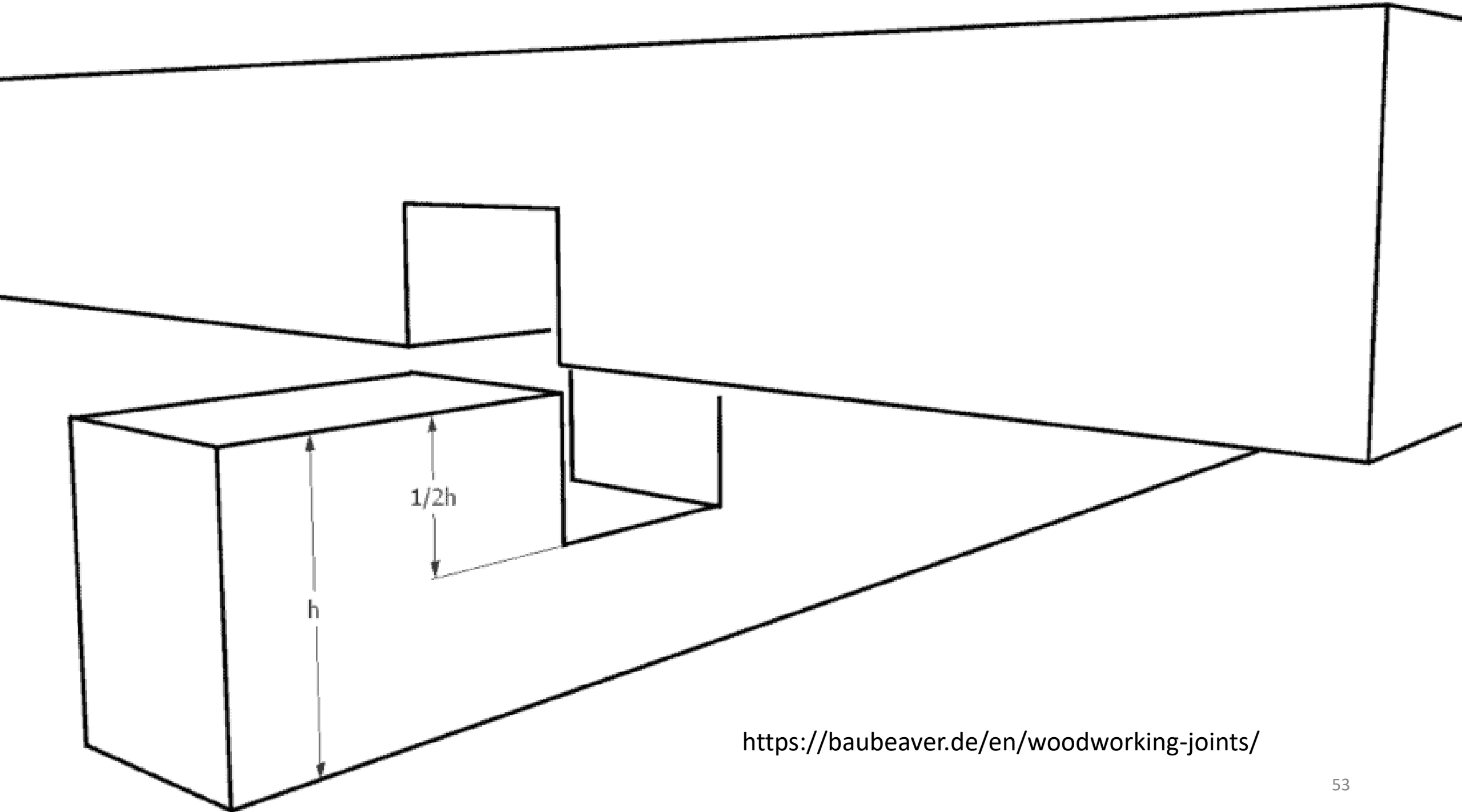

<https://baubeaver.de/en/woodworking-joints/>

<https://baubeaver.de/wp-content/uploads/woodworking-joints-Oblique-scarf-joint-with-hidden-hook.png>

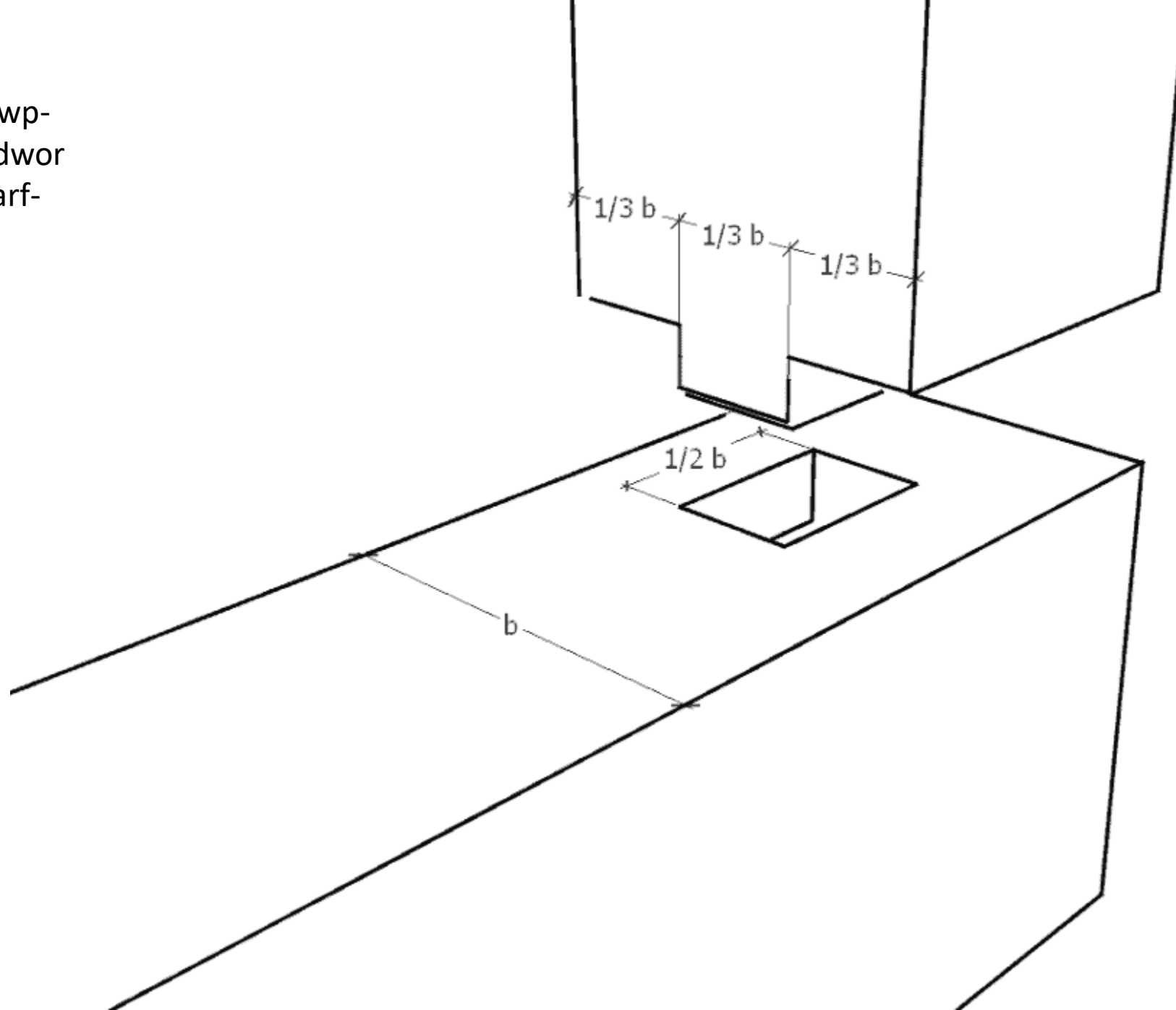

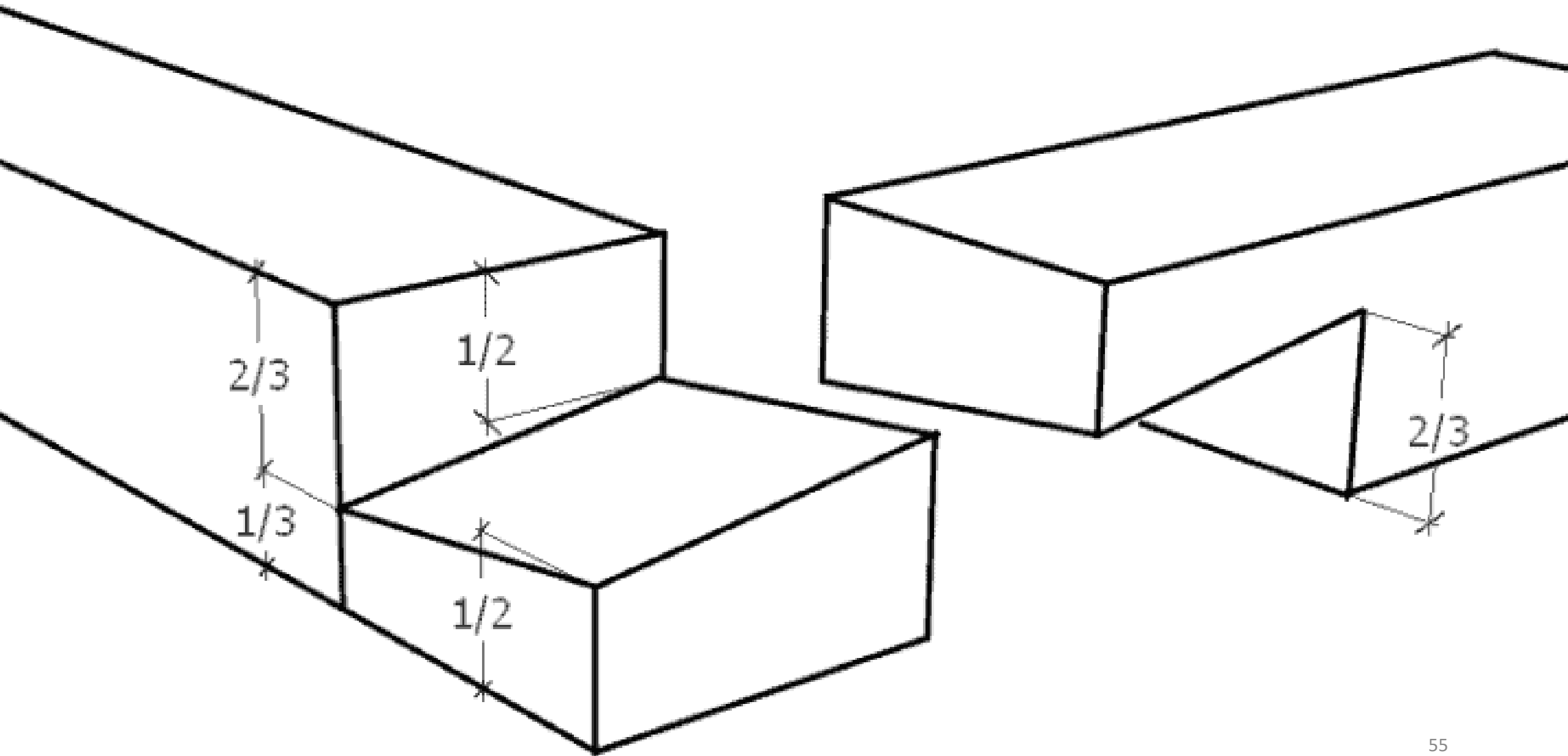

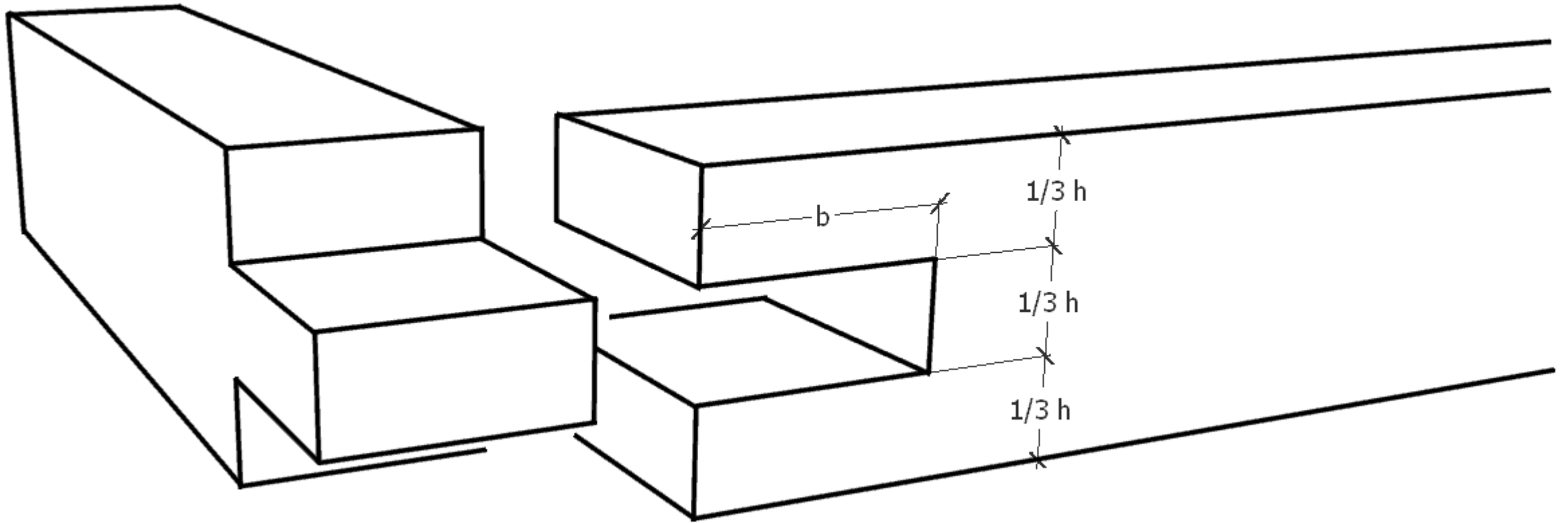

<https://baubeaver.de/wp-content/uploads/woodworking-joints-Oblique-scarf-joint-with-hidden-hook.png>



# Ligações: pilares com a fundação

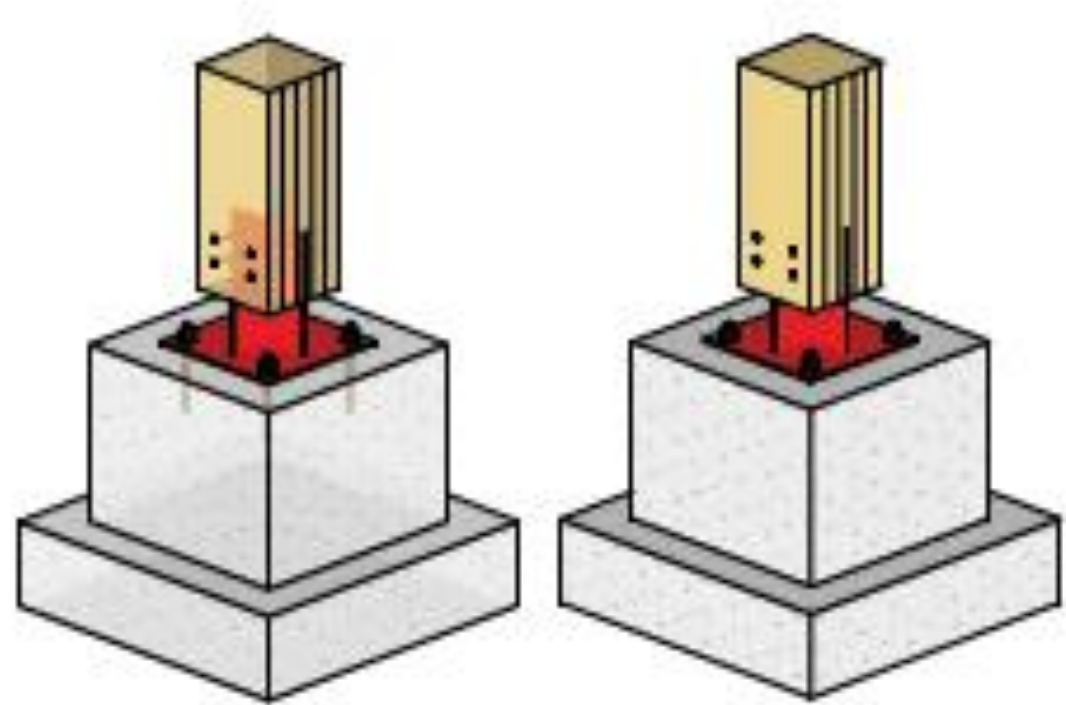
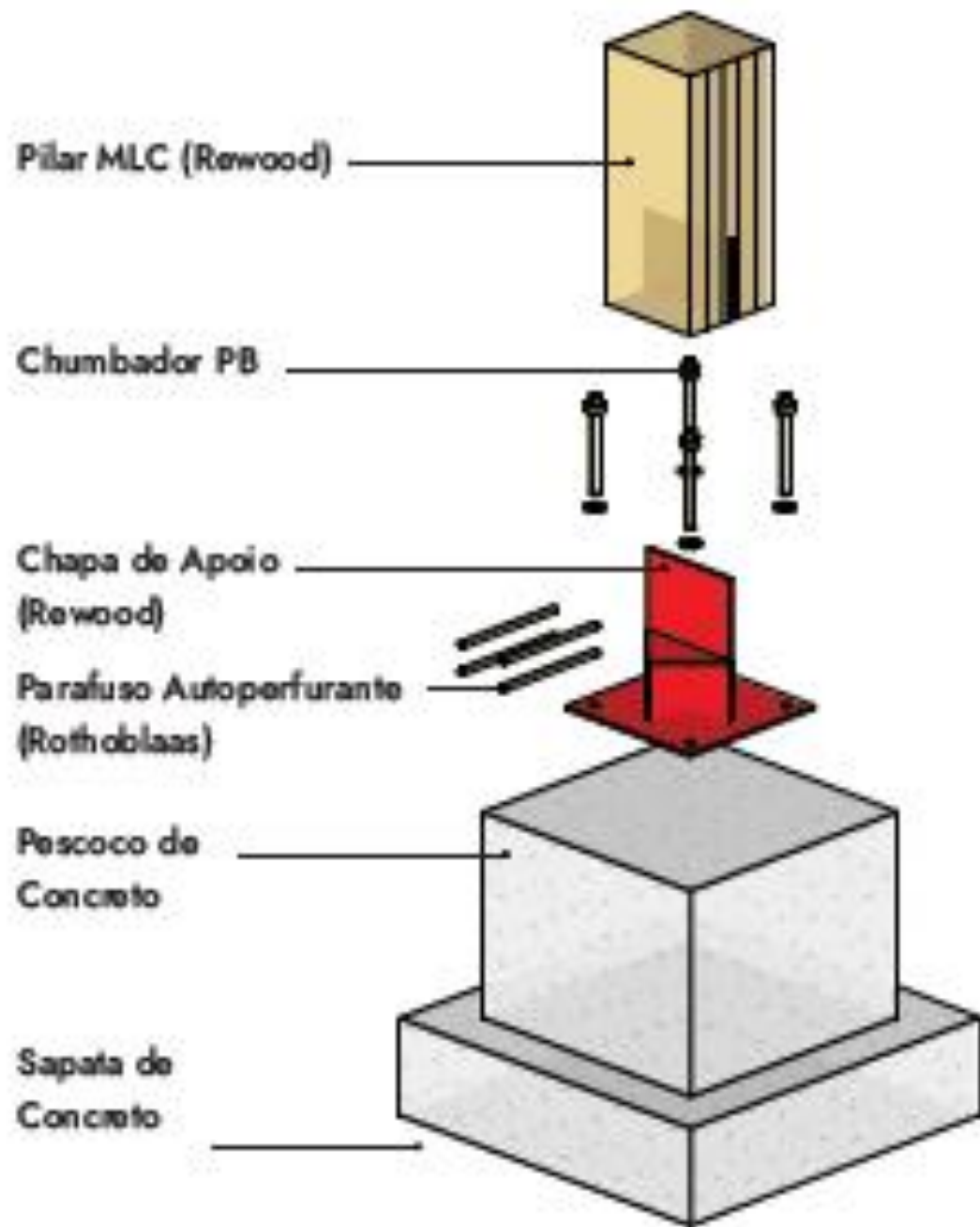

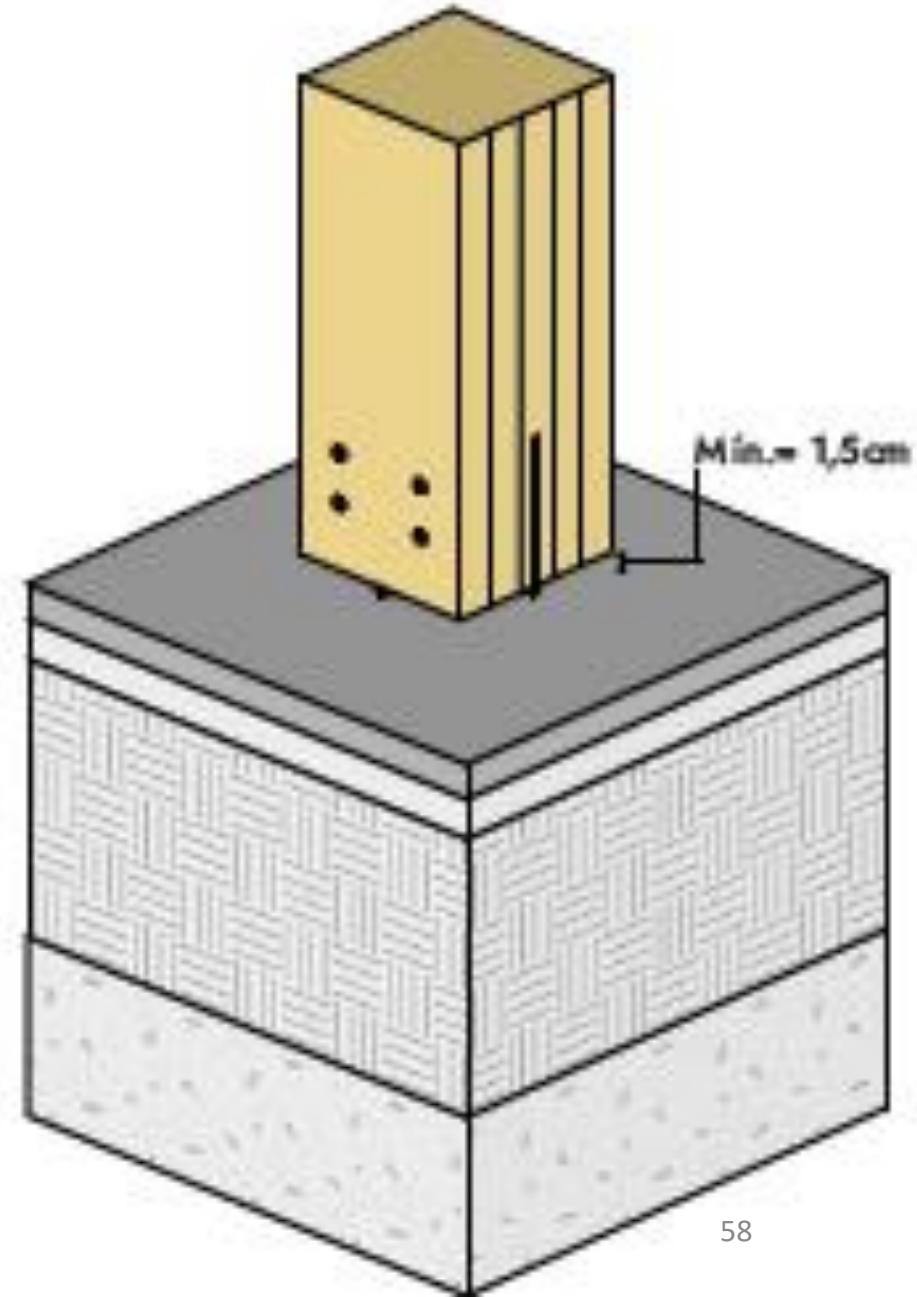
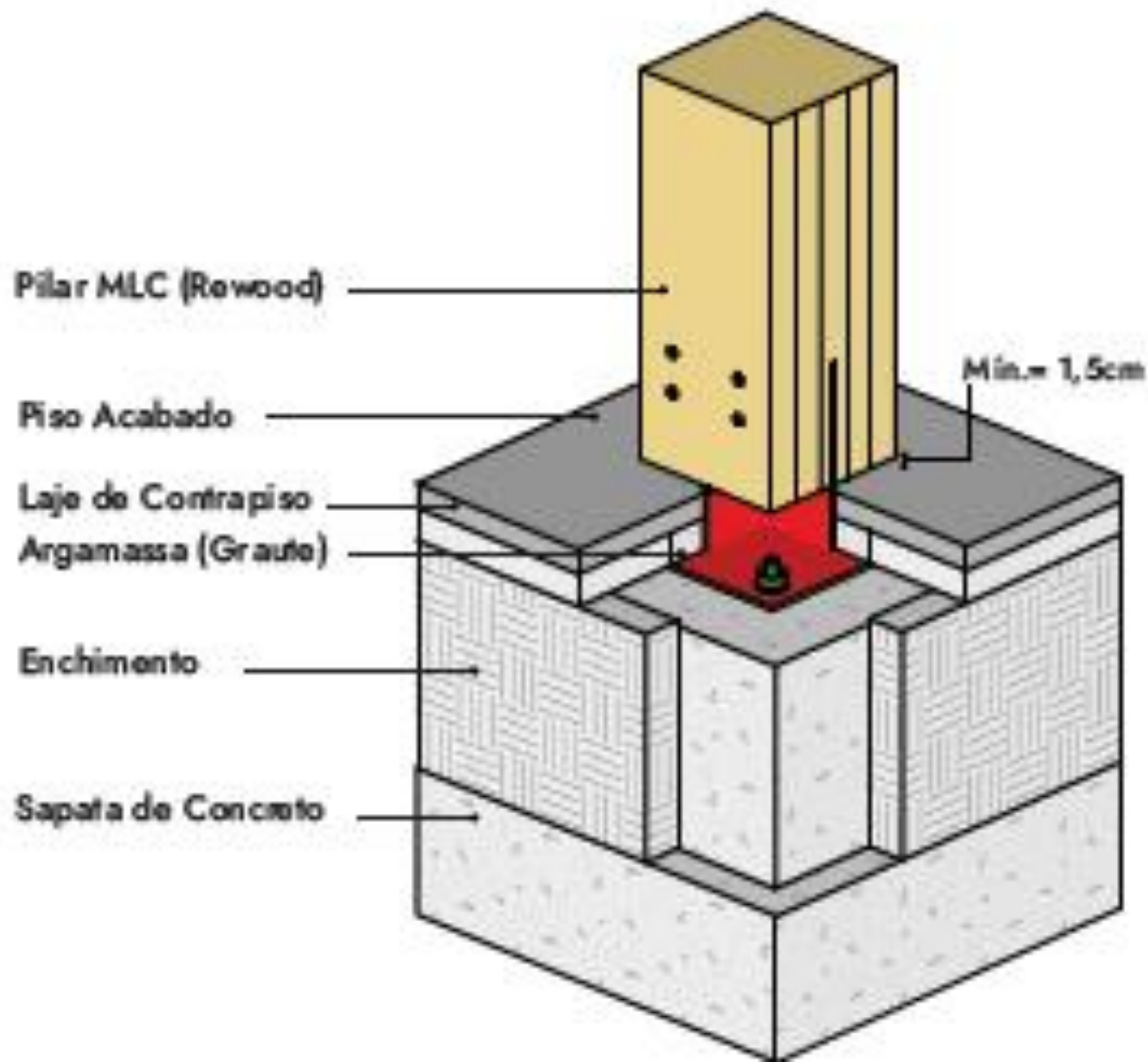

# REWOOD Caderno de detalhes

## construtivos.

São Paulo, 201-?

<https://rewood.com.br/wp-content/uploads/2020/04/Caderno-de-Detalhes-Construtivos-R07-2020.pdf>

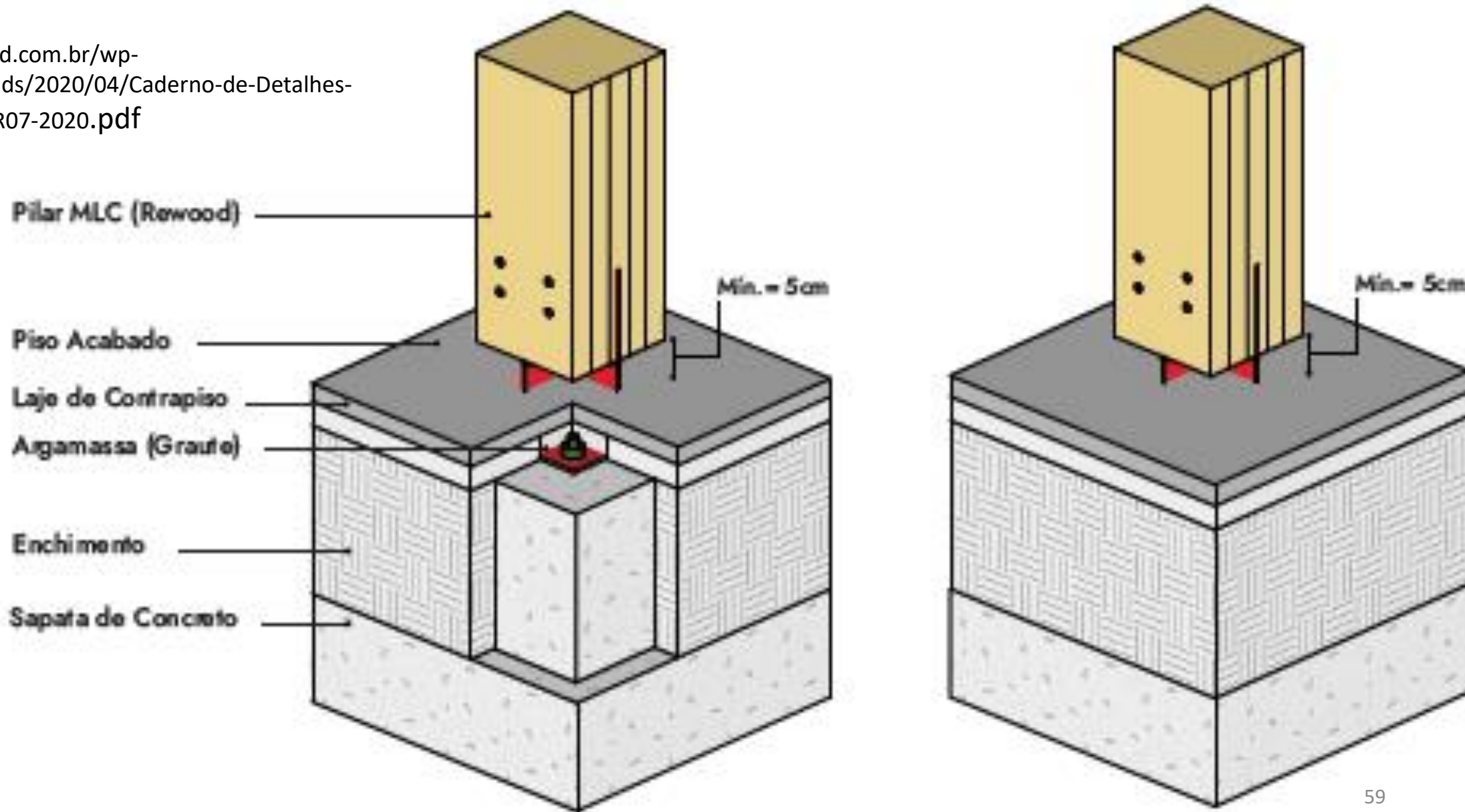

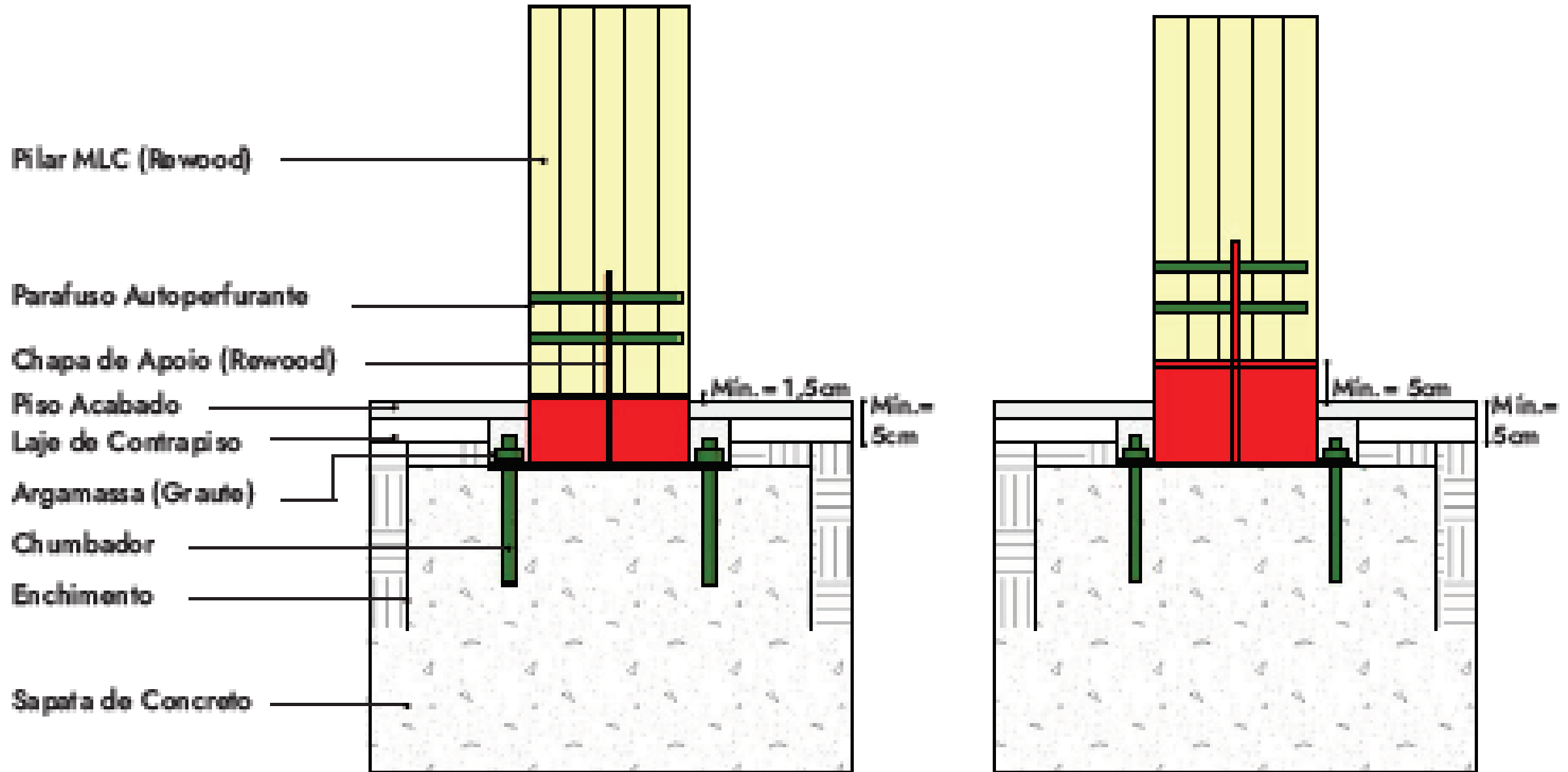



<https://www.archdaily.com.br/br/867547/15-conexoes-metalicas-para-estruturas-de-madeira-laminada-arauco/58111c7de58ece3701000003-15-metal-fittings-for-connecting-laminated-wooden-structures-beam-to-beam-joints>

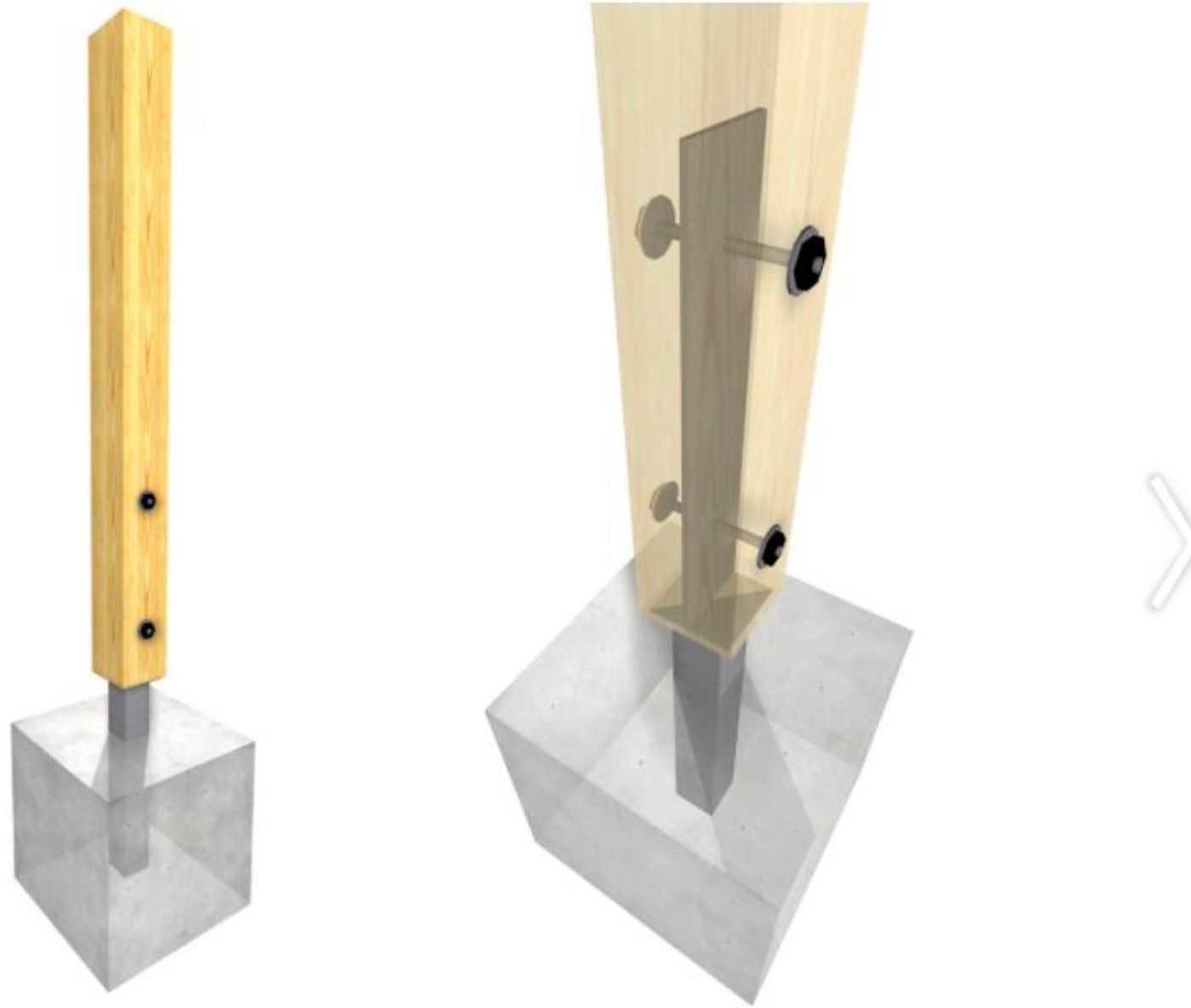

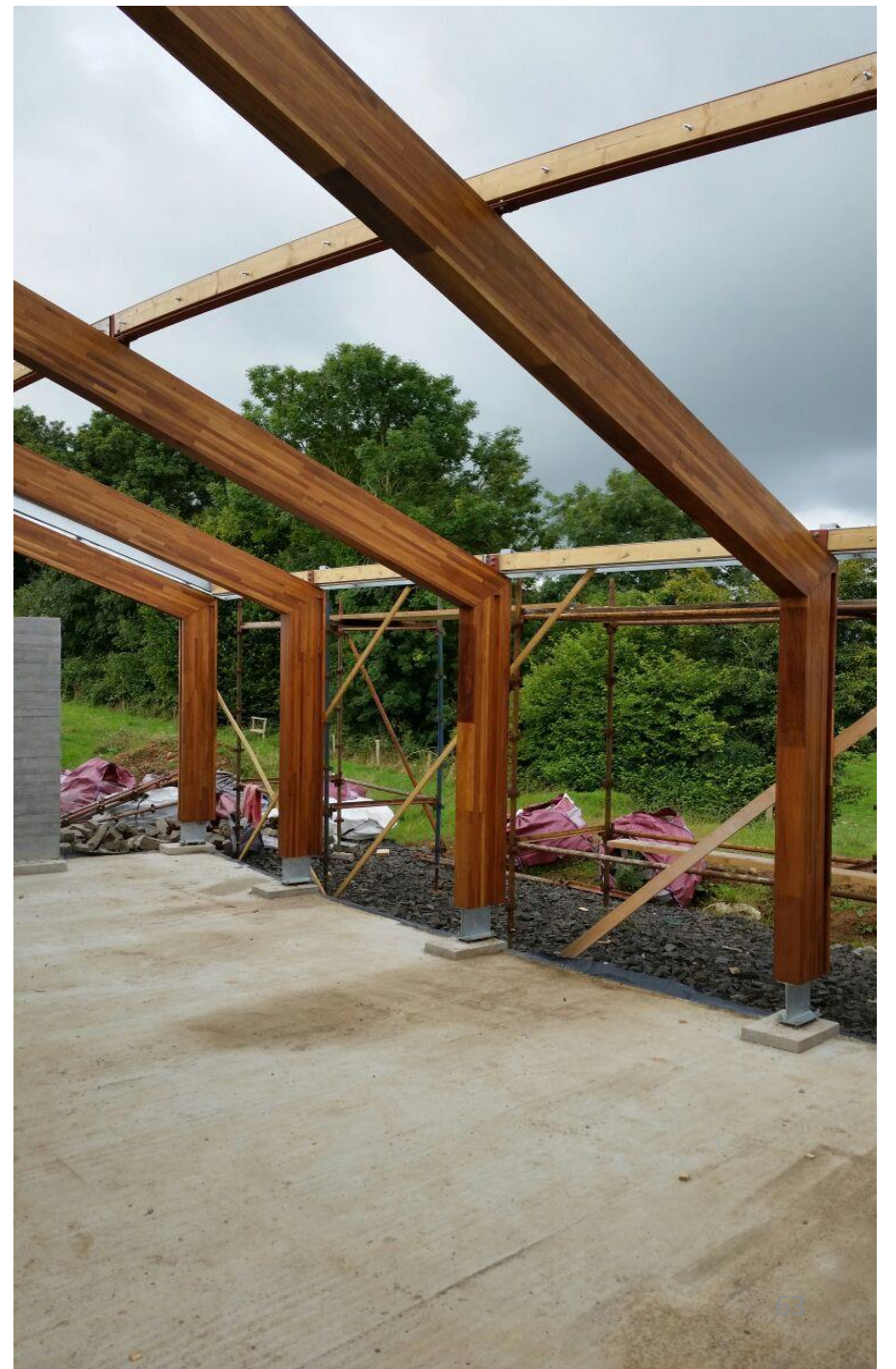





# Zaunpfosten mit Stützenschuh



<https://schroeffuinding.nl/blokhutten-schuren-en-tuinhuisjes/>



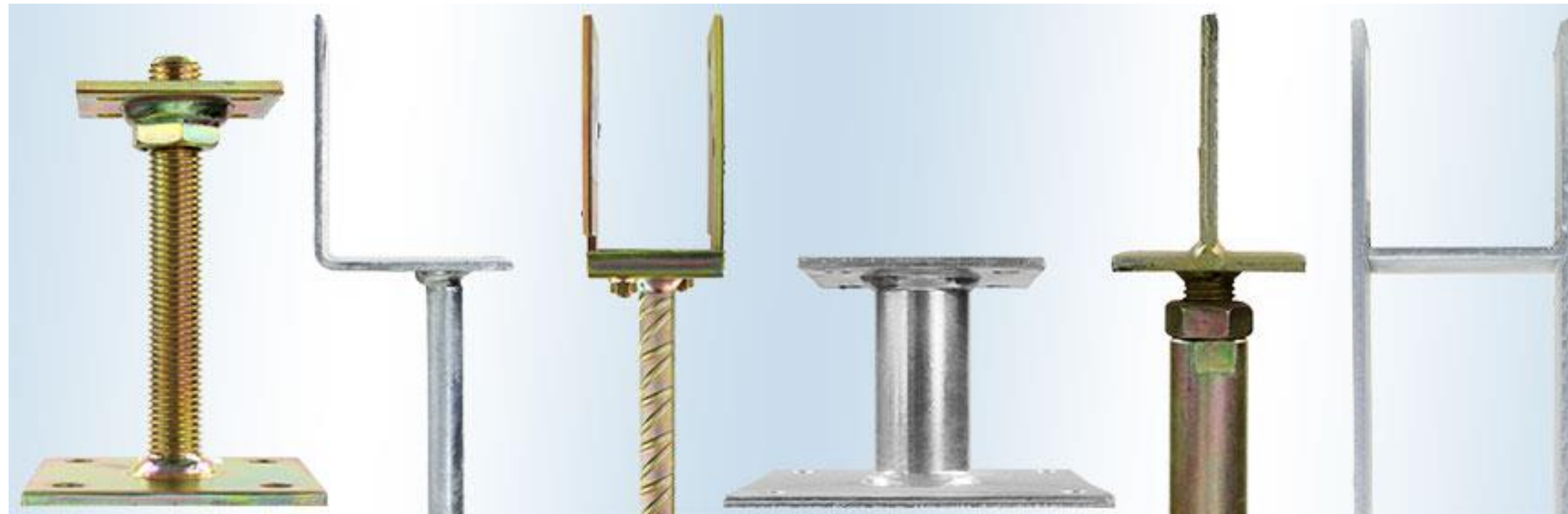

<https://www.befestigungsfuchs.de/blog/anforderungen-pfostentraeger/>





Embrèvement  
avant

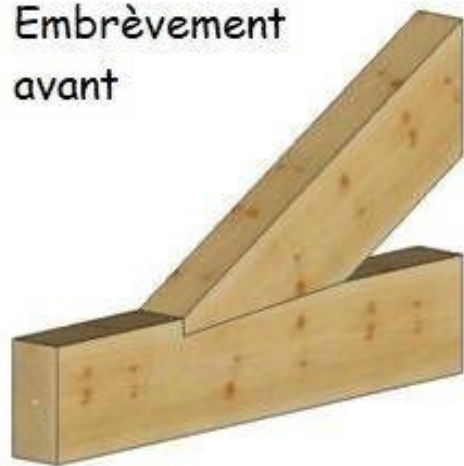

Embrèvement  
arrière



Embrèvement  
double

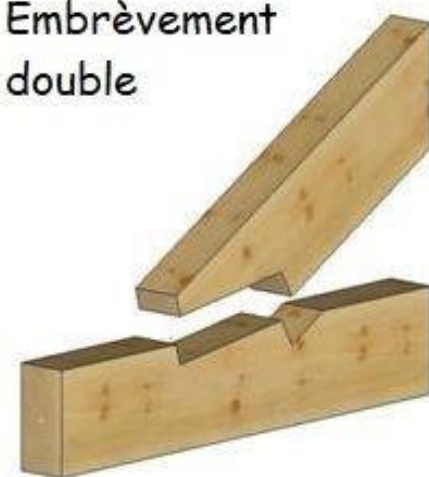

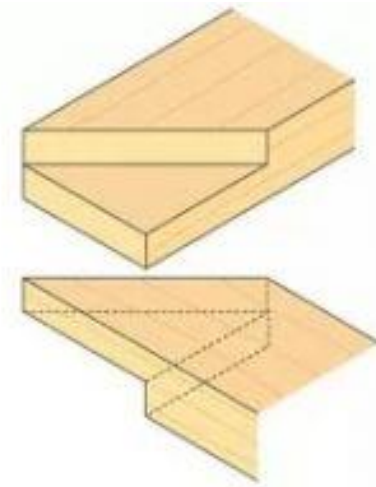
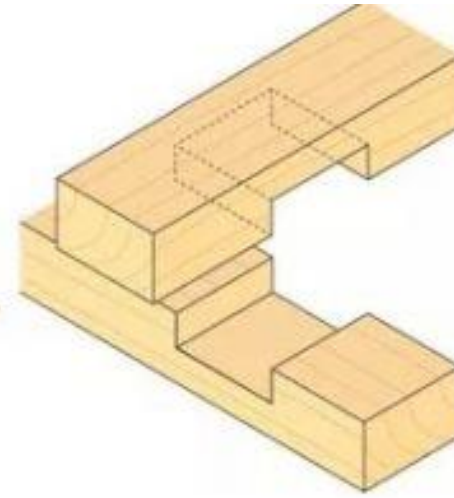
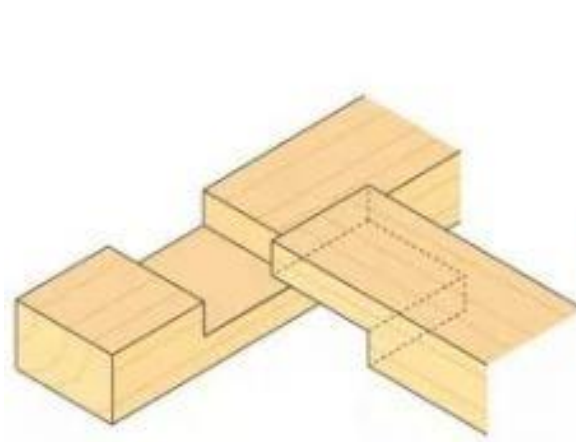
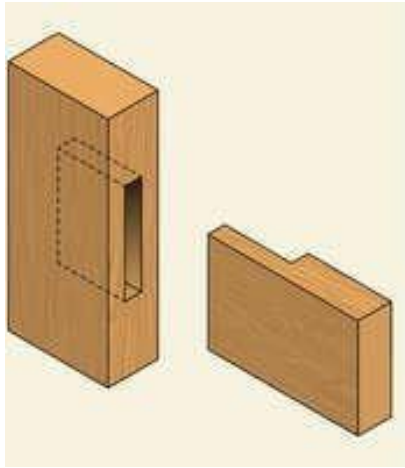

Mi-bois en bout

Mi-bois en "T"

Mi-bois d'onglet

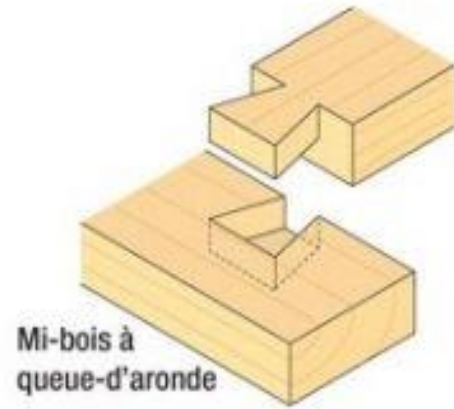

Mi-bois à  
queue-d'aronde

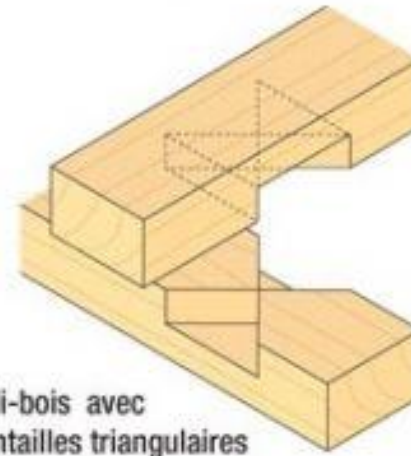

Mi-bois avec  
entailles triangulaires

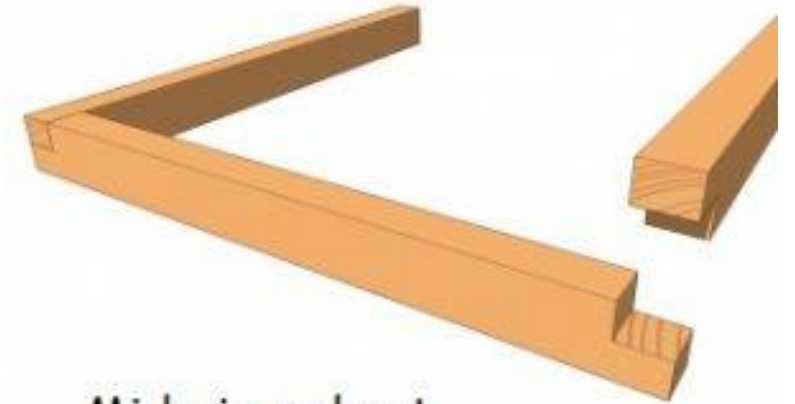

Mi-bois en bout

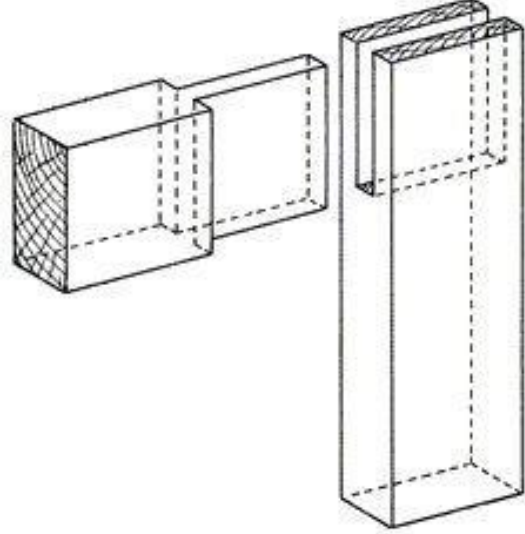

Enfouchement simple

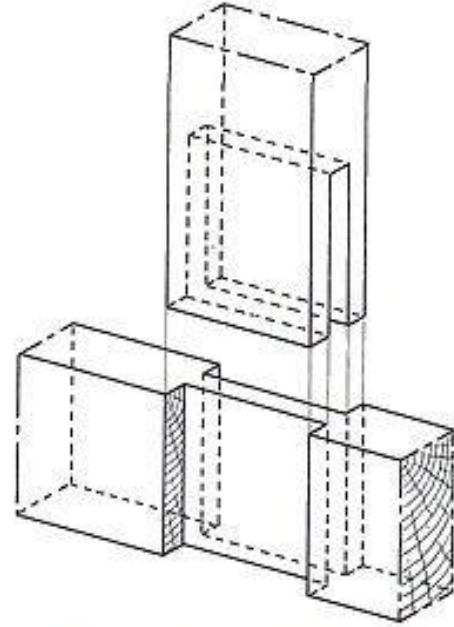

Enfouchement en T

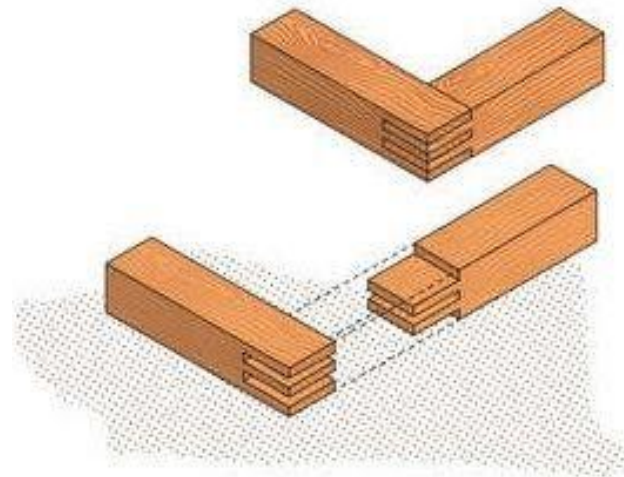

Enfouchement double

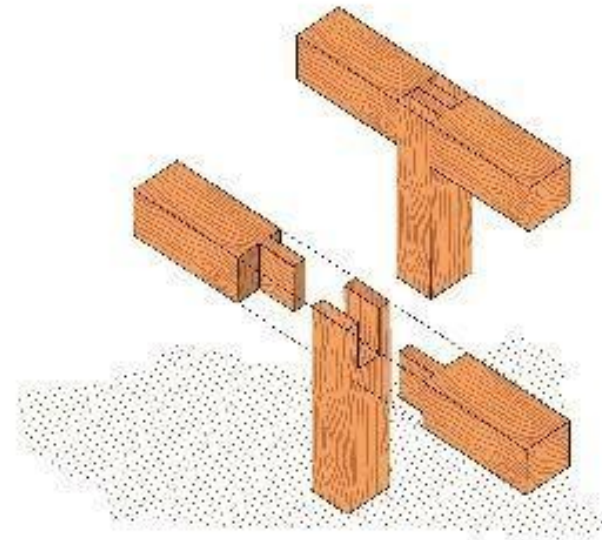

Enfouchement multiple



Coupe à sifflet désabouté avec crochet



Trait de jupiter



Enture de mi-bois

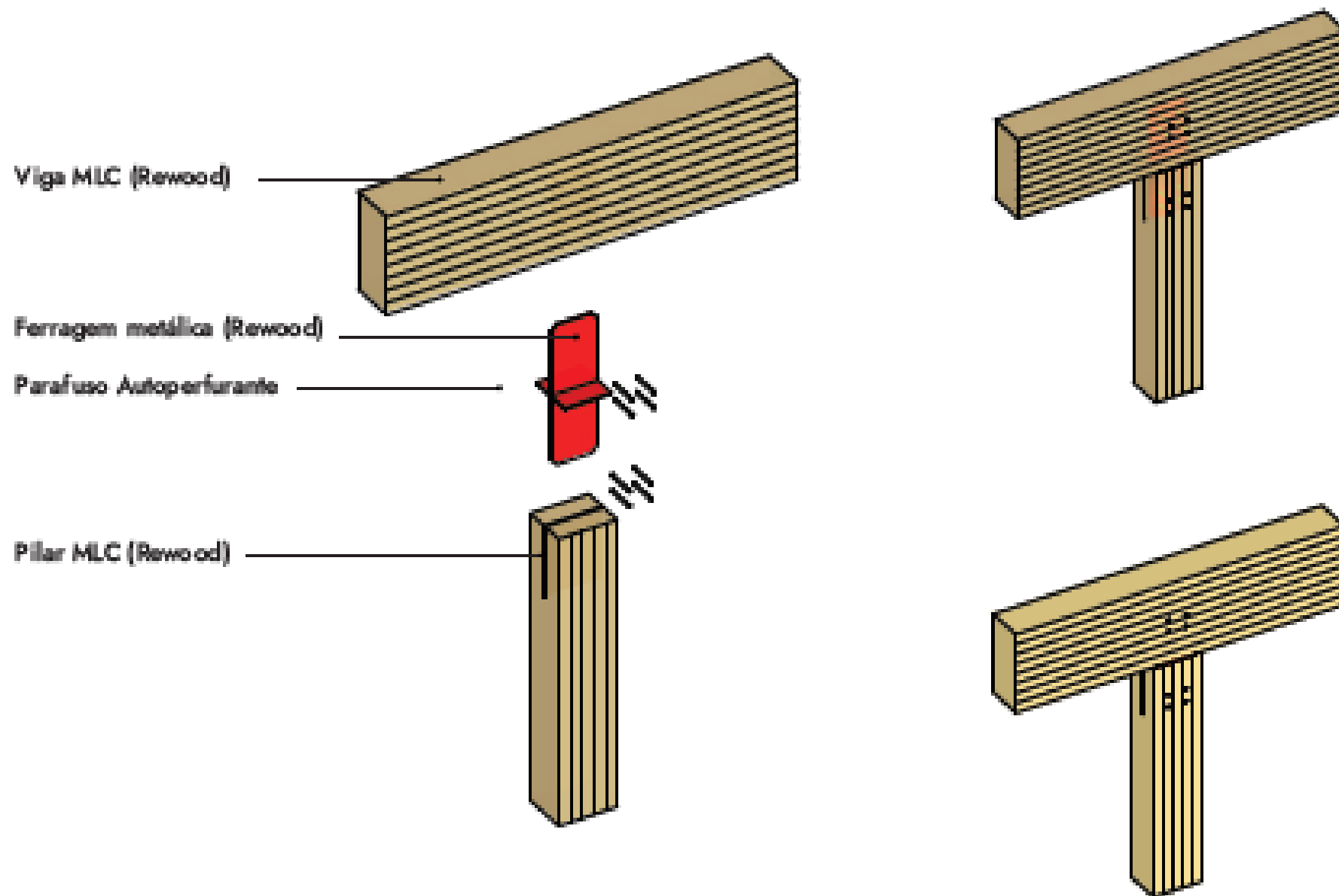

A.09 Fixação da viga no pilar 2



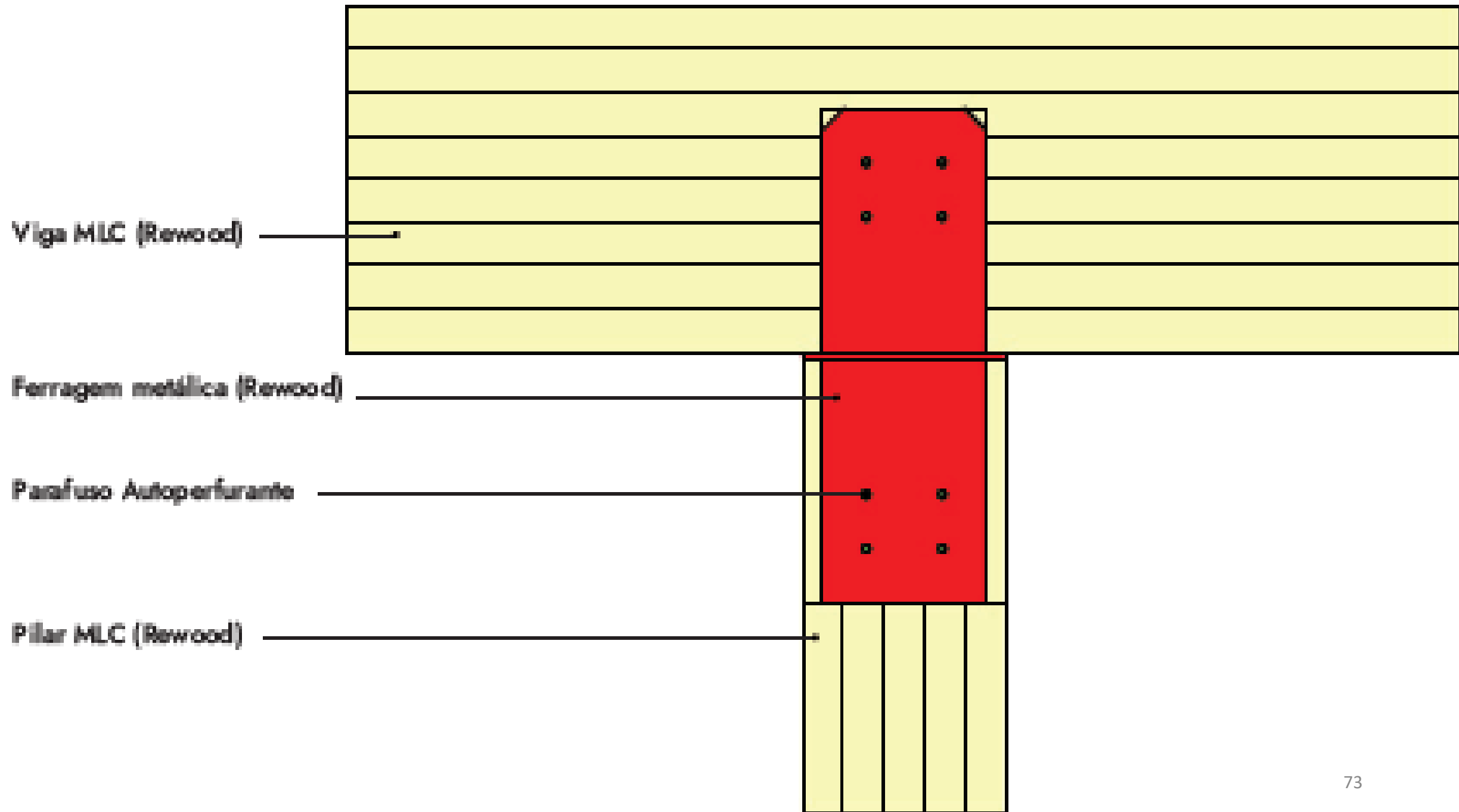

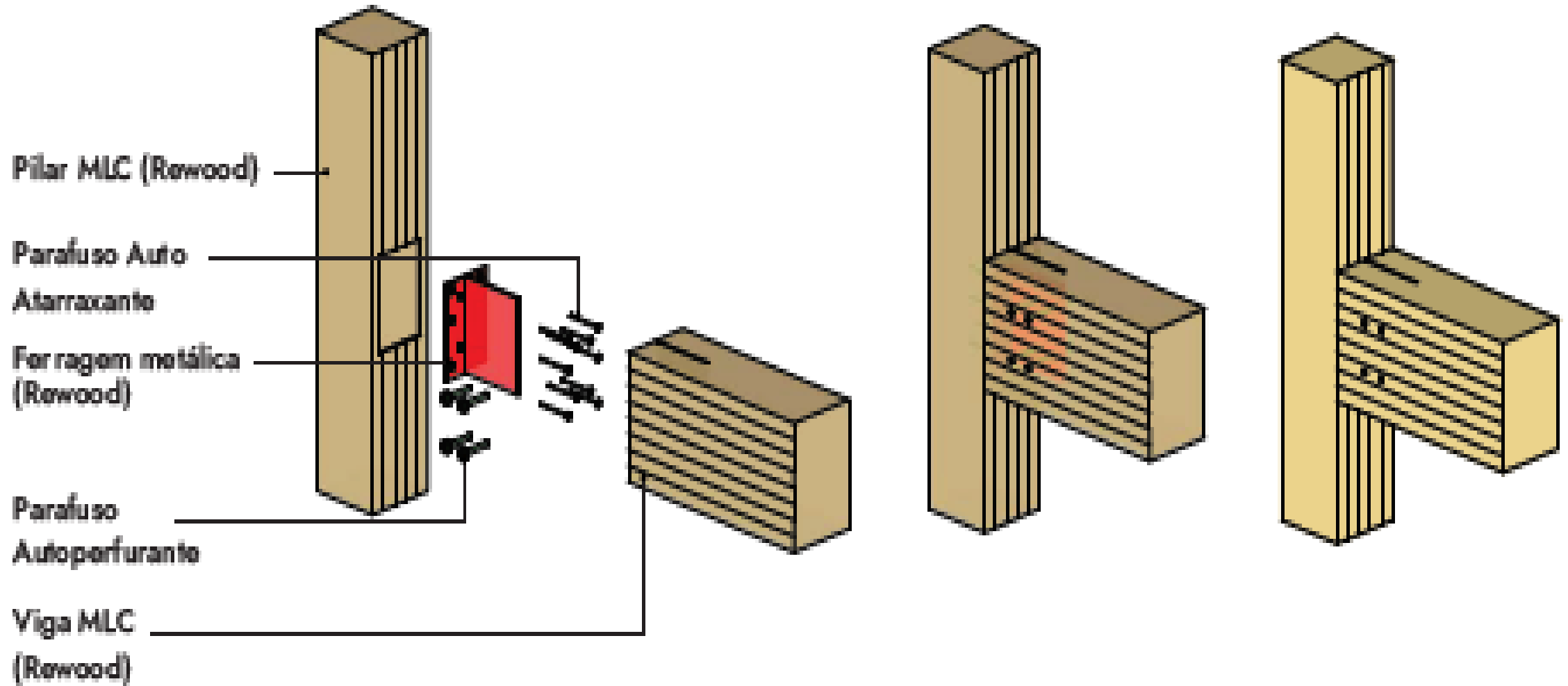

## ÁREA INTERNA

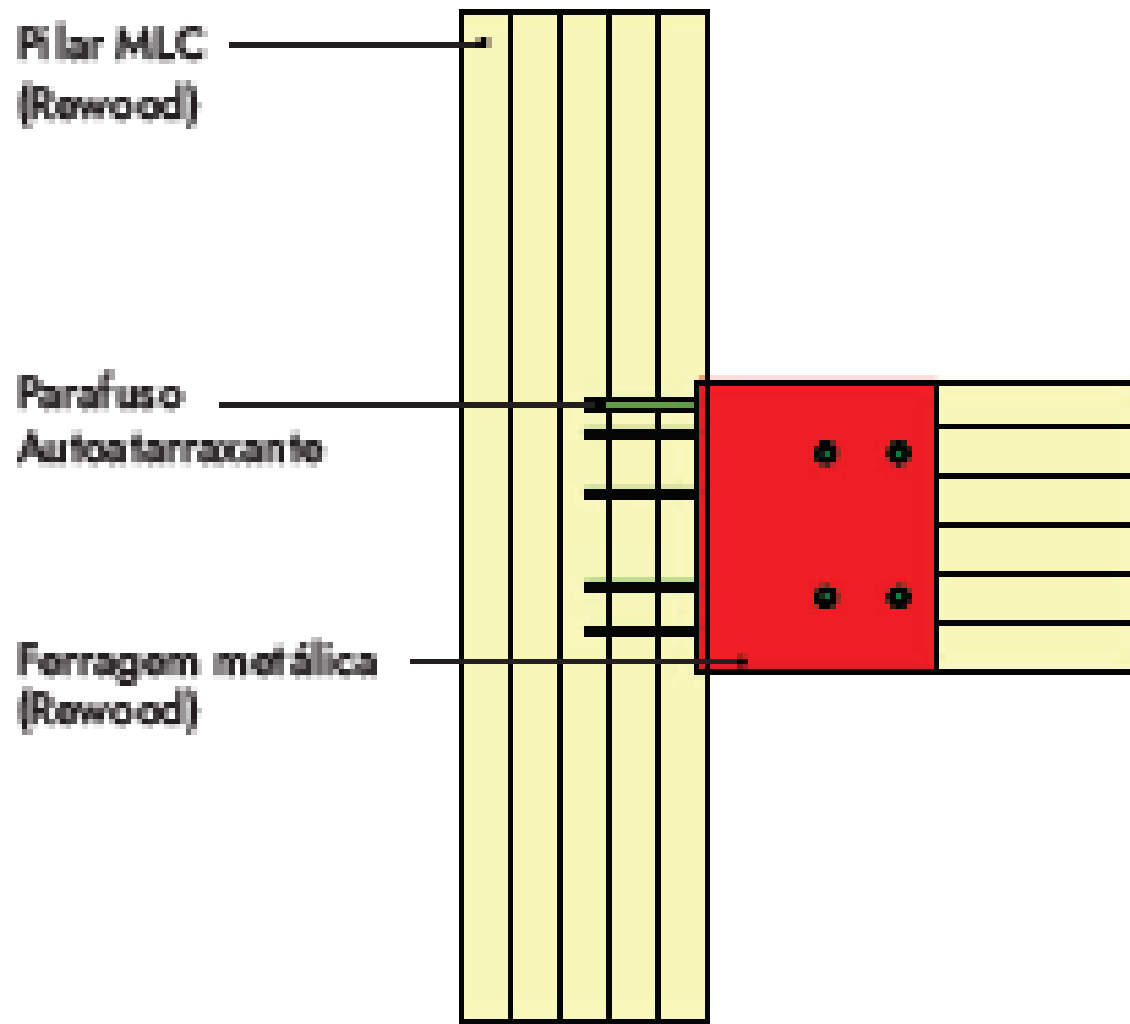

## ÁREA EXTERNA

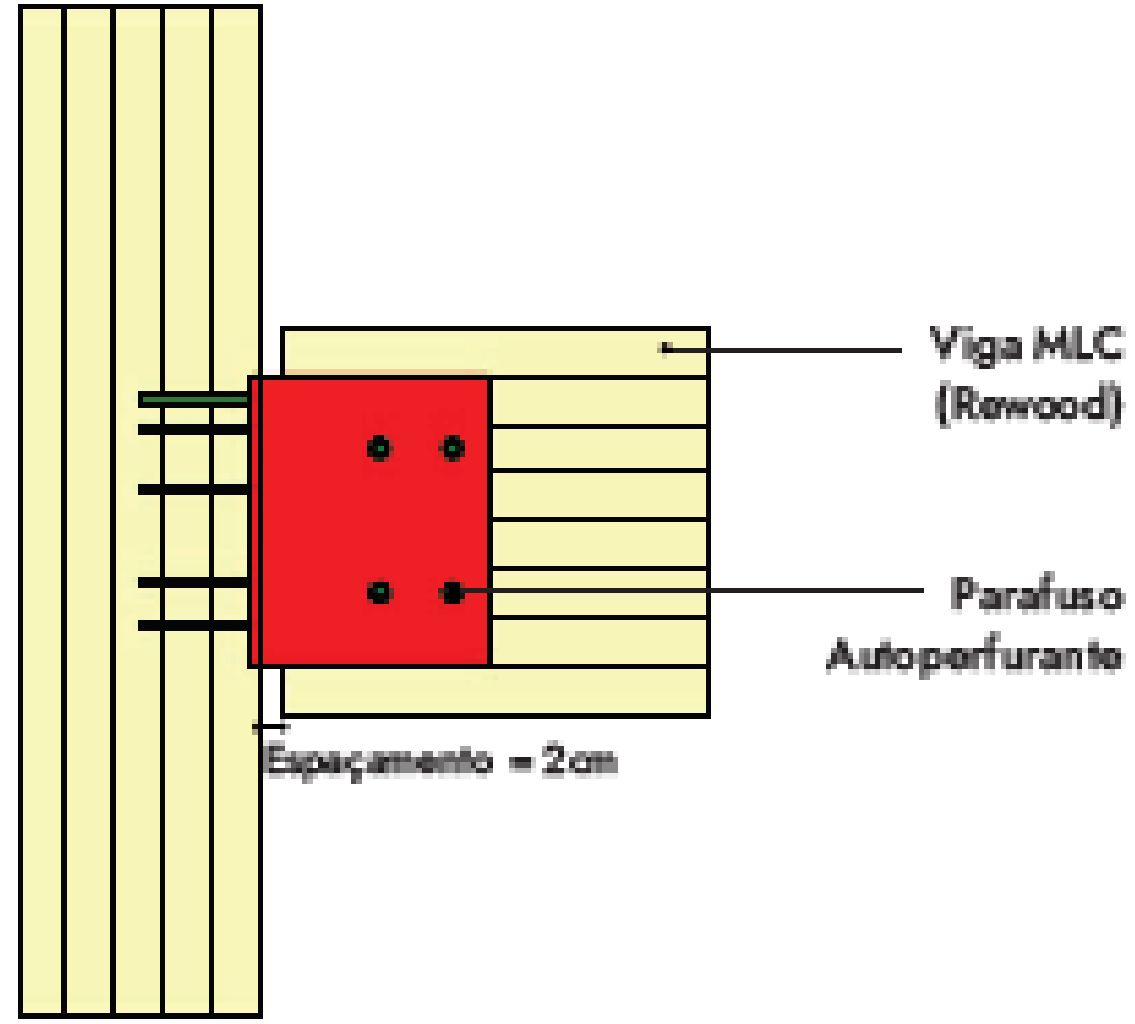

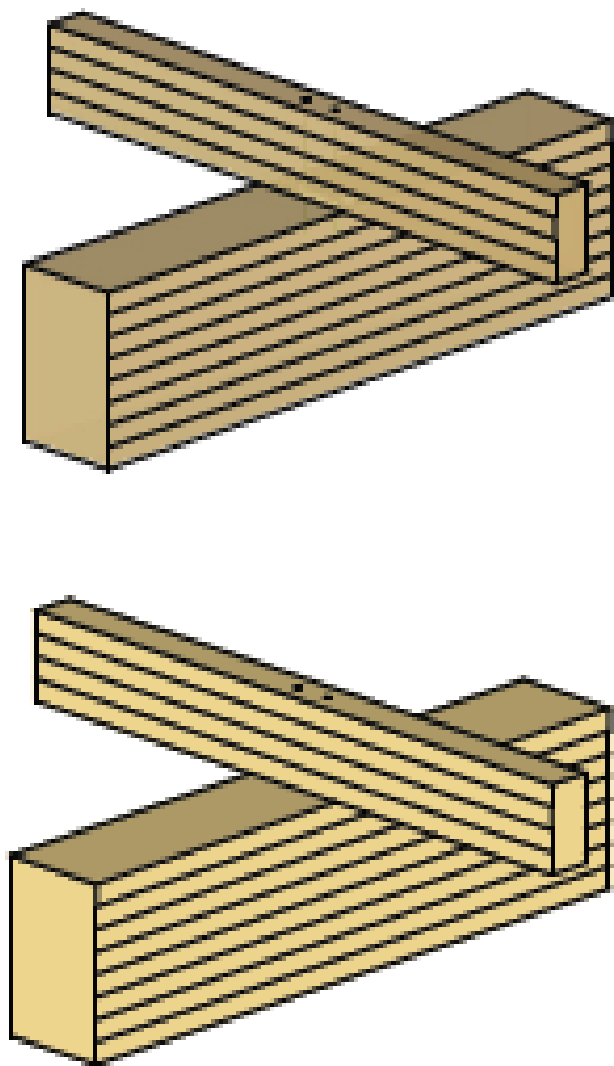
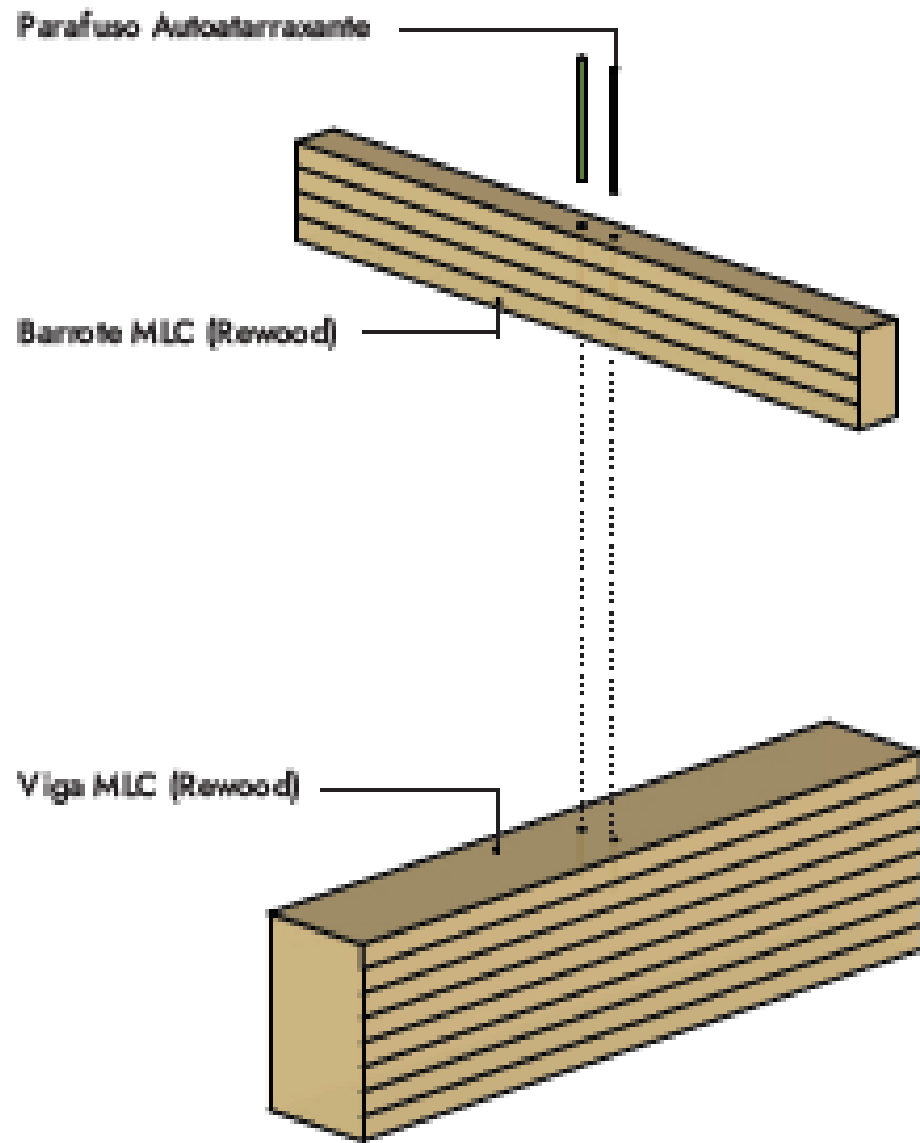

A.07 Fixação do barrote sobreposto na viga

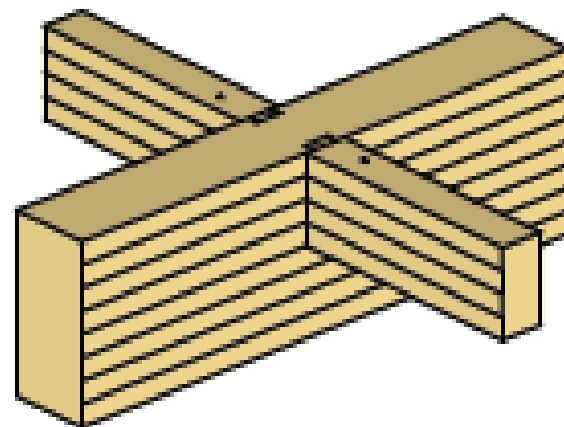
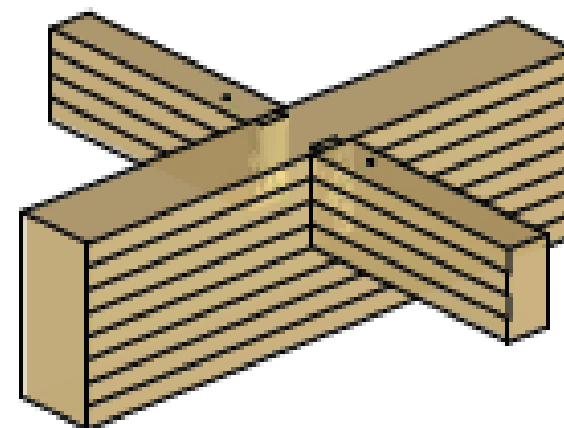
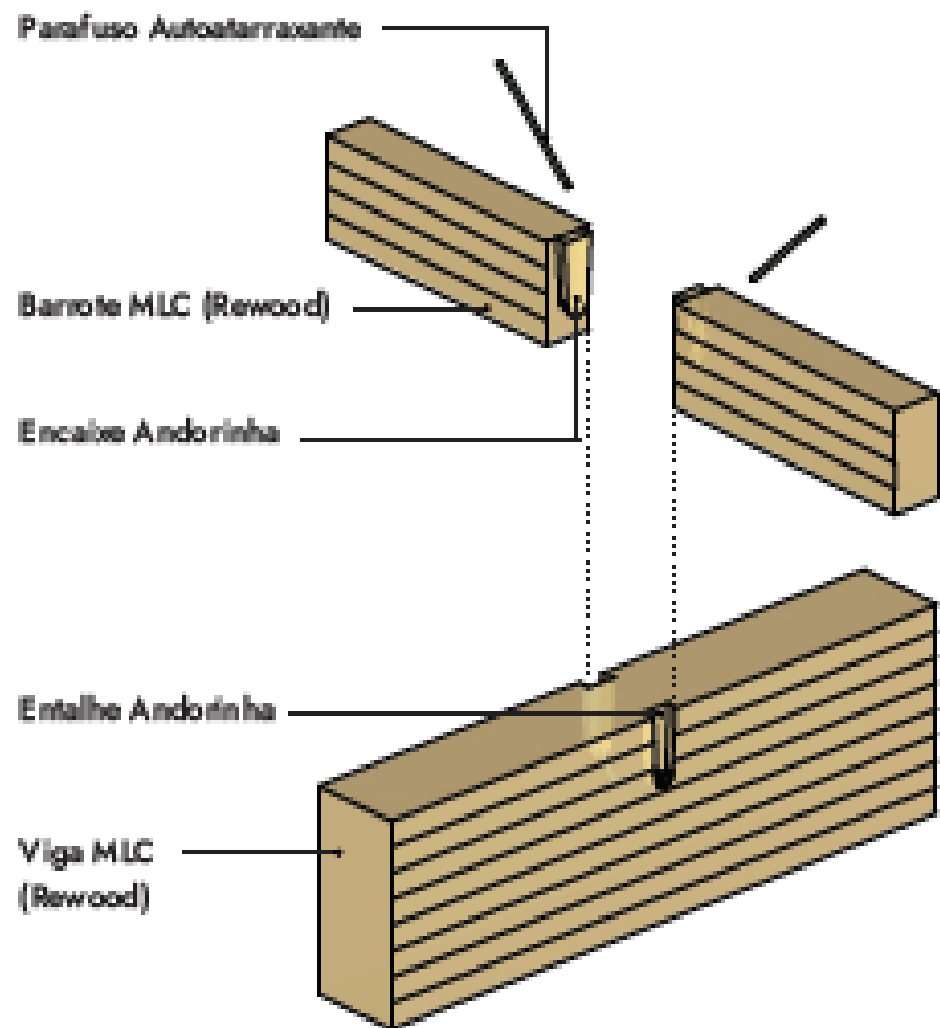

A.08 Fixação do barrote coplanar na viga com entalhe andorinha



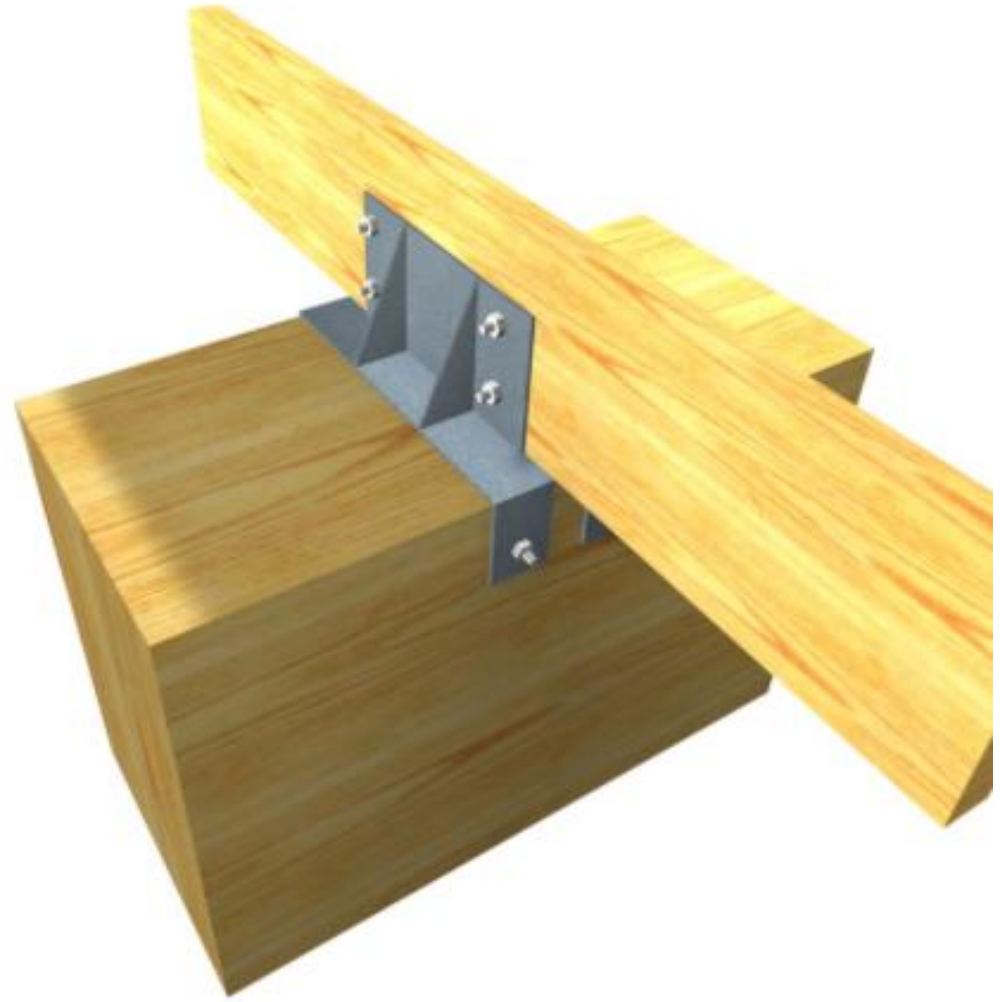
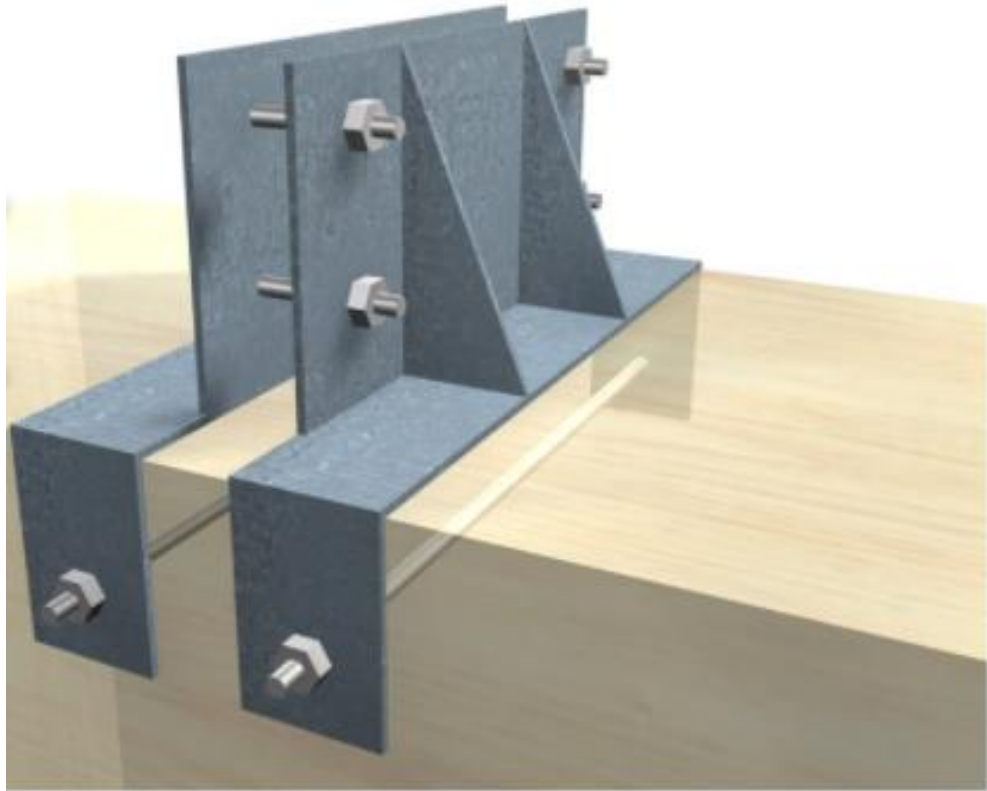

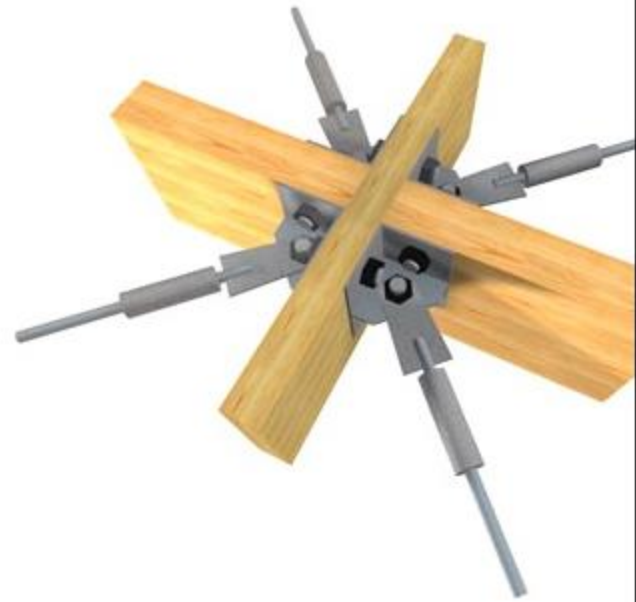
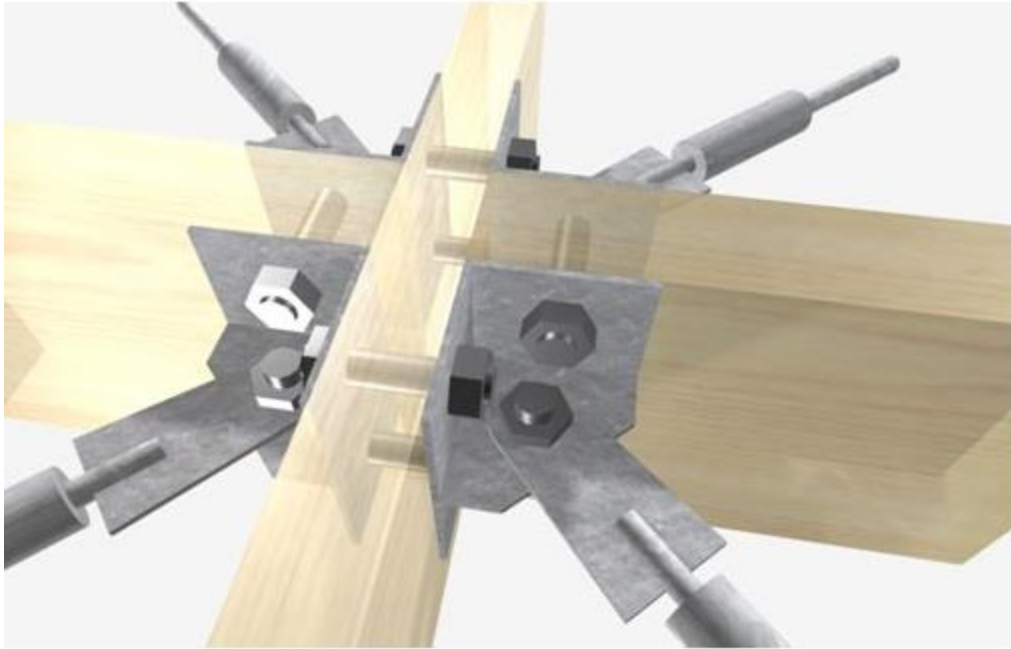



[www.archdaily.com/804991/15-metal-fittings-for-connecting-laminated-wooden-structures/5819fc75e58eceeef60002fd-15-metal-fittings-for-connecting-laminated-wooden-structures-](http://www.archdaily.com/804991/15-metal-fittings-for-connecting-laminated-wooden-structures/5819fc75e58eceeef60002fd-15-metal-fittings-for-connecting-laminated-wooden-structures-)

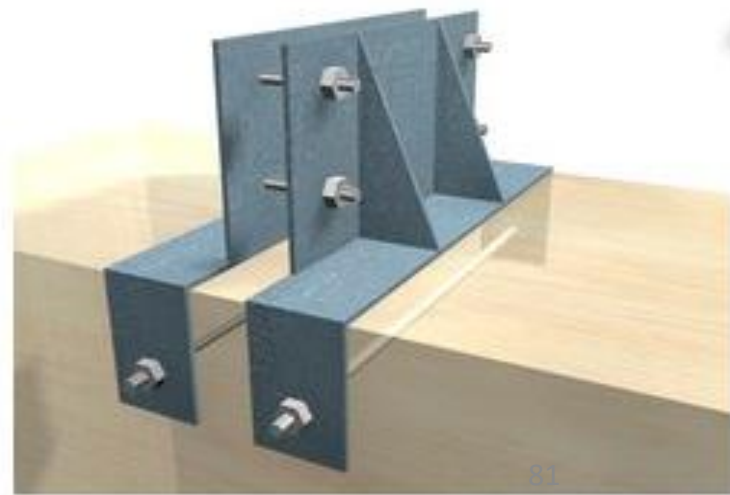
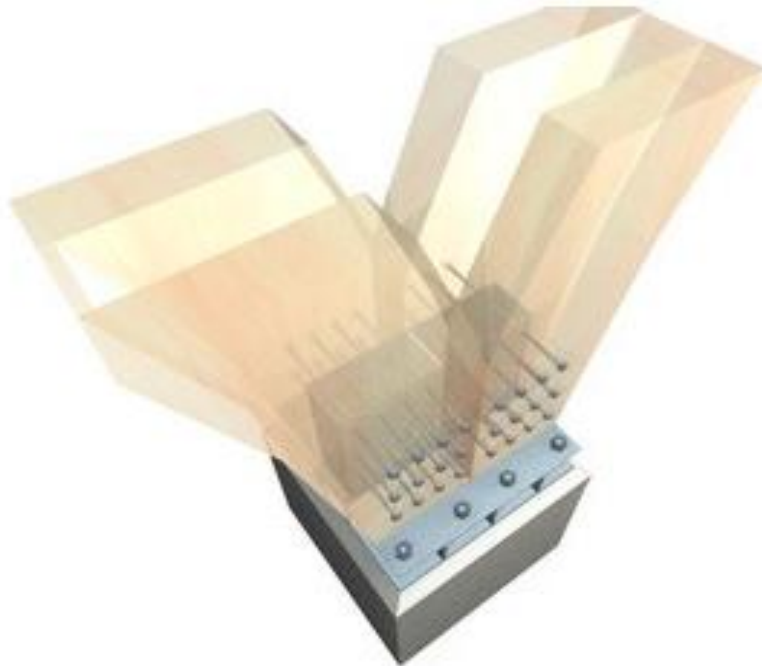
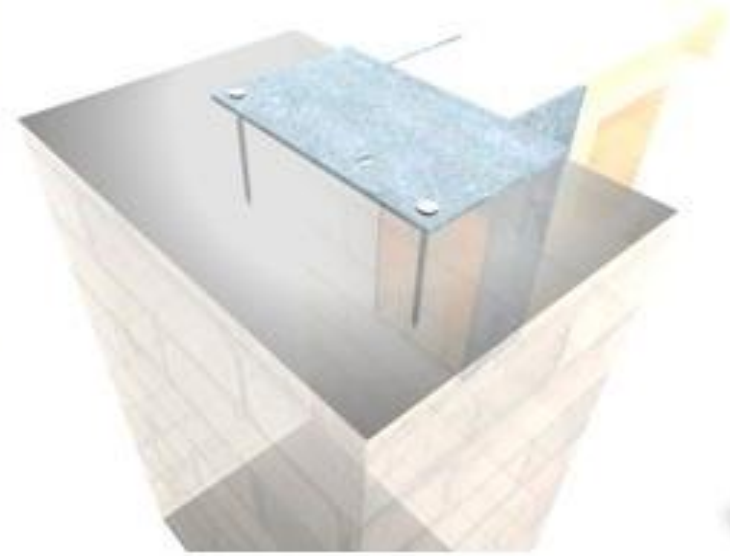

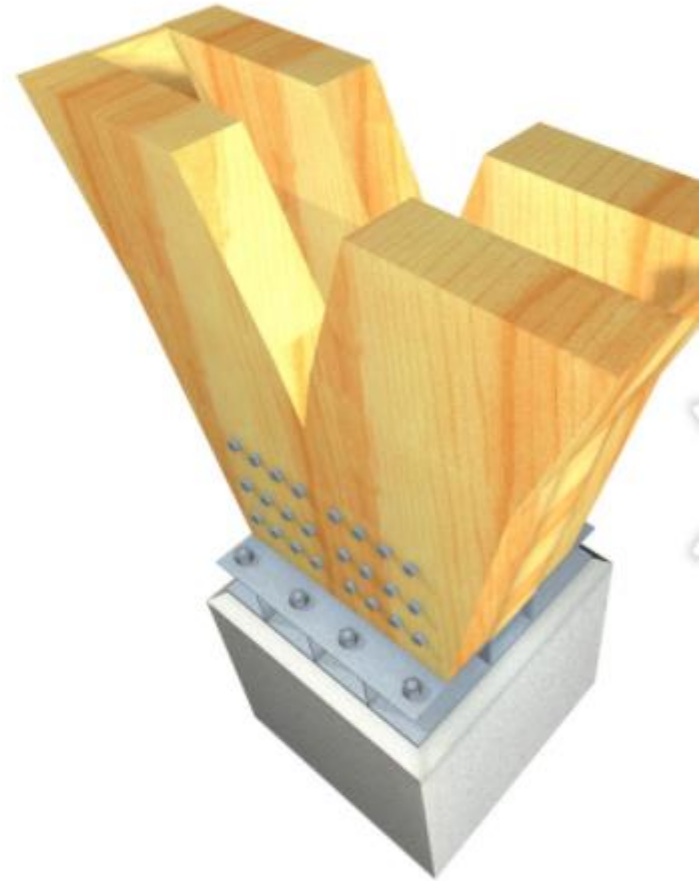
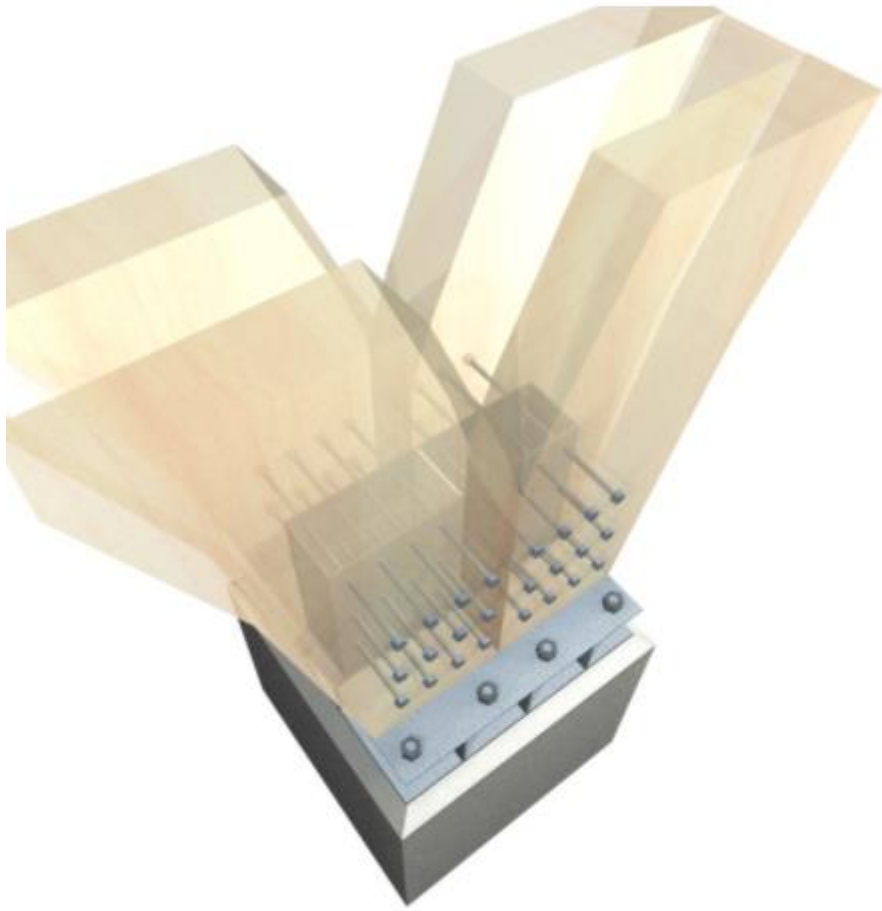

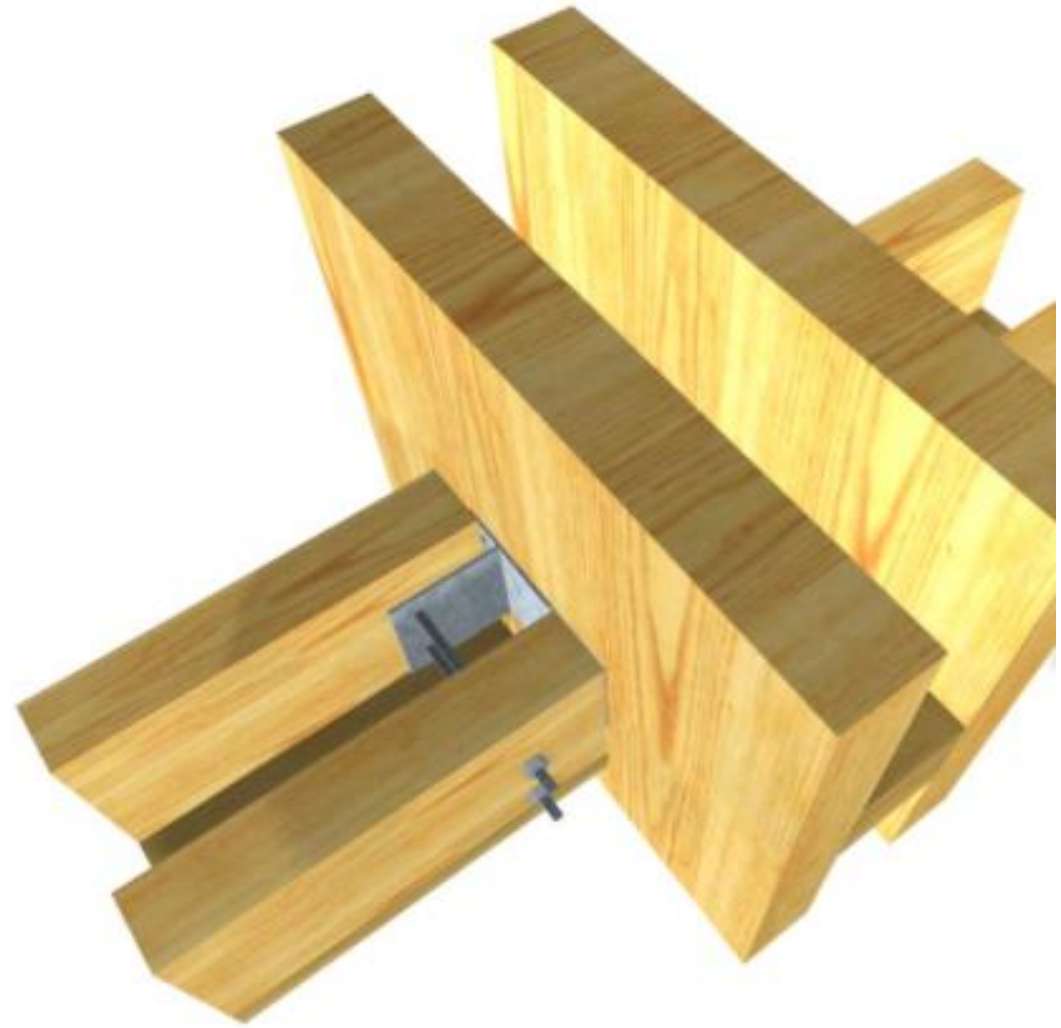
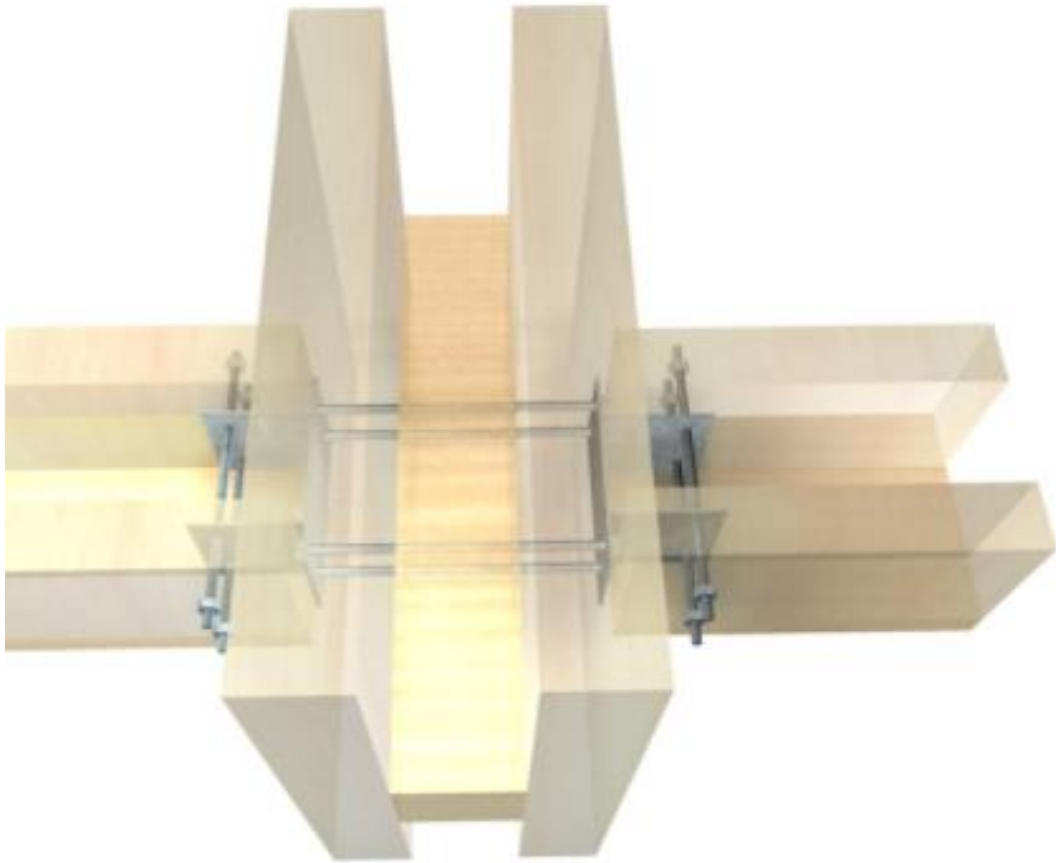

<https://www.archdaily.com.br/br/867547/15-conexoes-metalicas-para-estruturas-de-madeira-laminada-arauco/58111c7de58ece3701000003-15-metal-fittings-for-connecting-laminated-wooden-structures-beam-to-beam-joints>

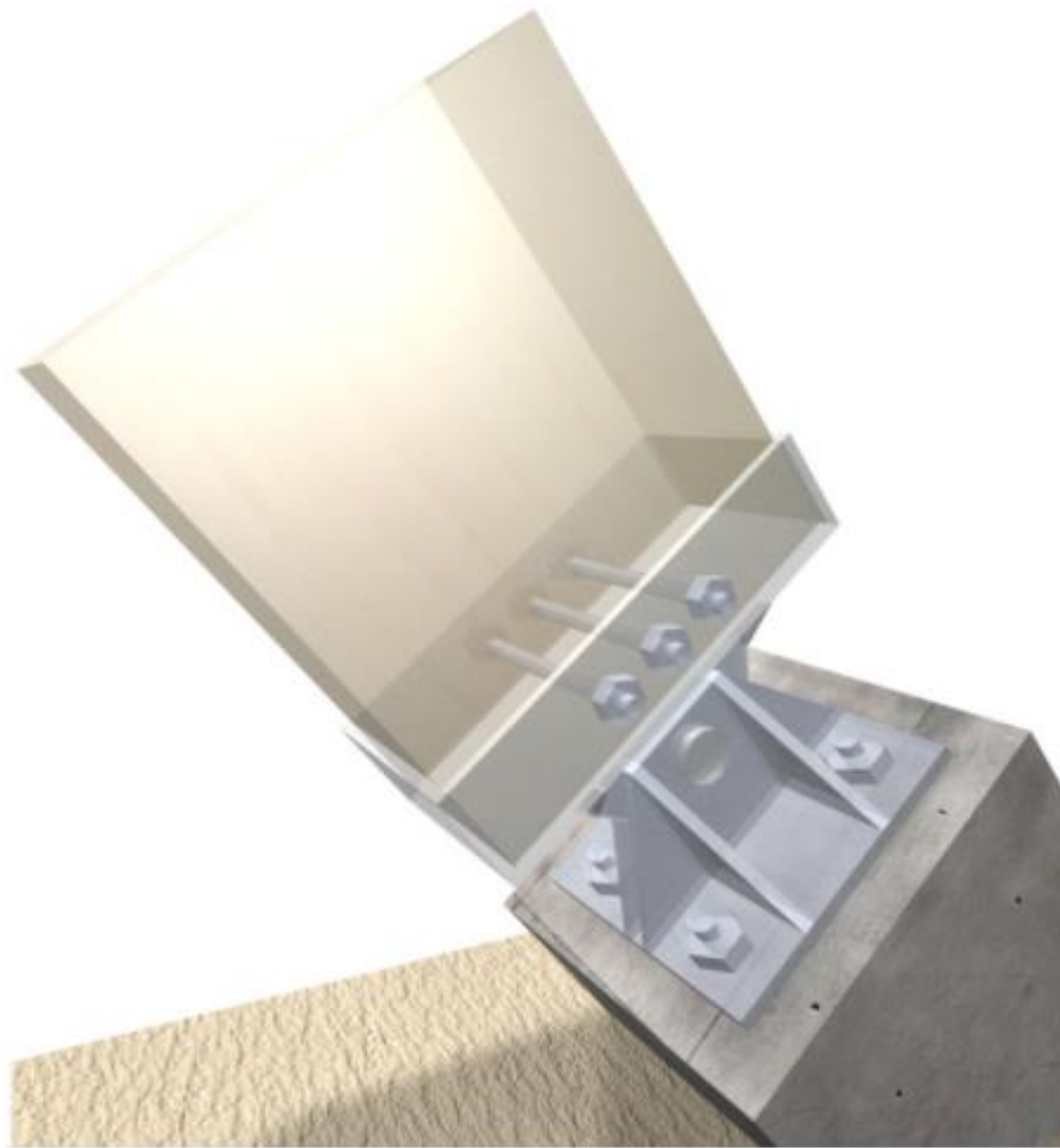
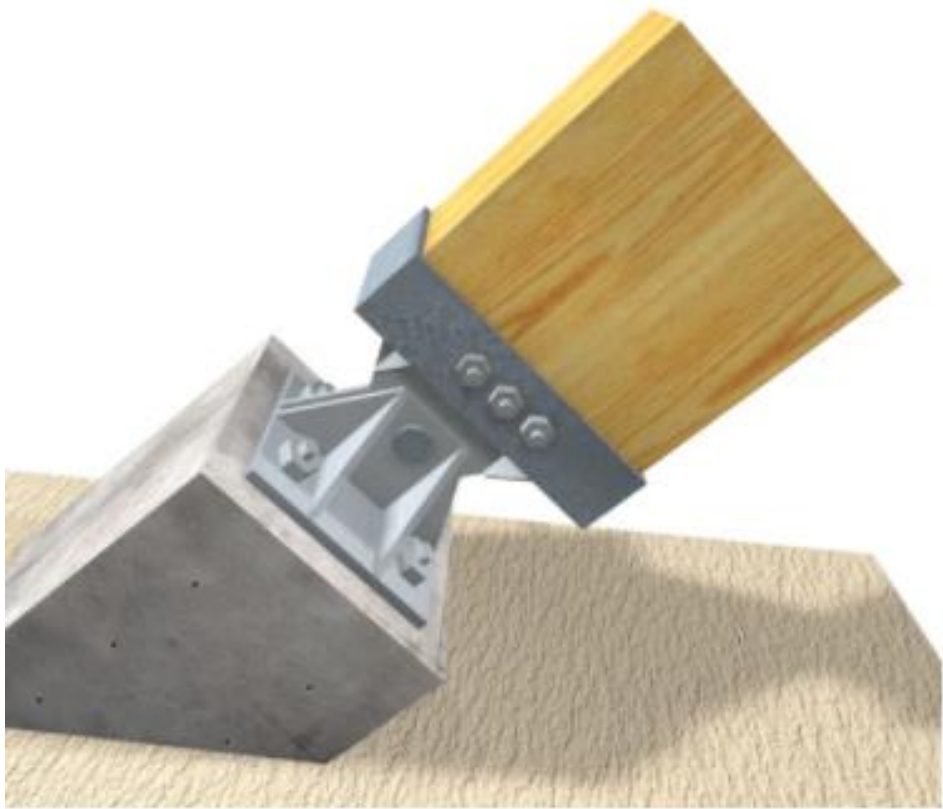



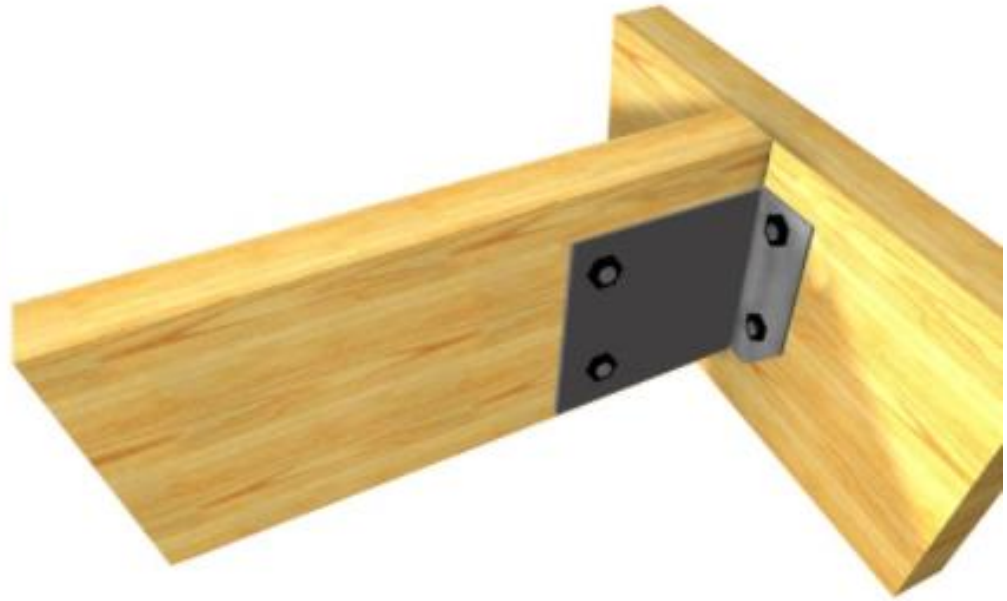
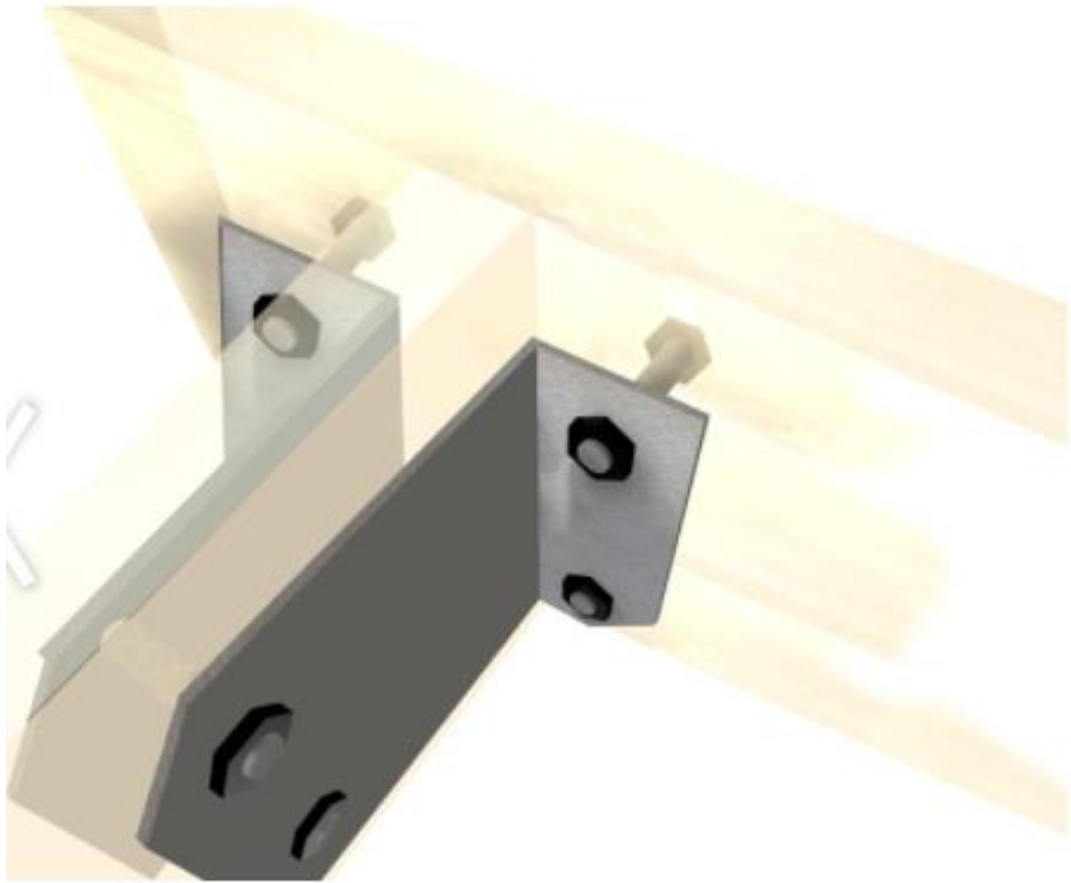



<https://www.archdaily.com.br/br/867547/15-conexoes-metalicas-para-estruturas-de-madeira-laminada-arauco/58111c7de58ece3701000003-15-metal-fittings-for-connecting-laminated-wooden-structures-beam-to-beam-joints>

<https://www.archdaily.com.br/br/867547/15-conexoes-metalicas-para-estruturas-de-madeira-laminada-arauco/58111c7de58ece3701000003-15-metal-fittings-for-connecting-laminated-wooden-structures-beam-to-beam-joints>

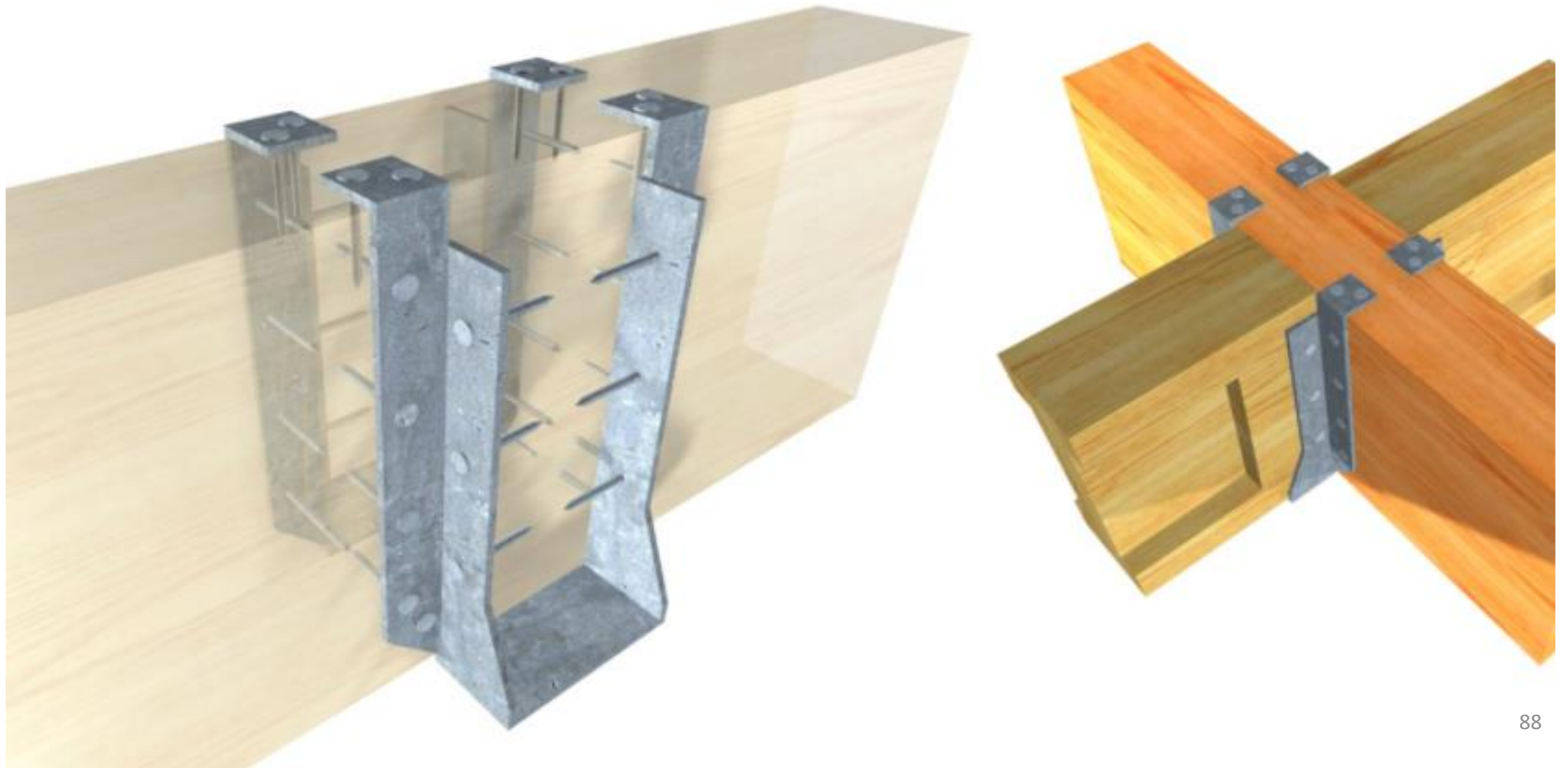



[https://www.archdaily.com.br/br/927919/como-unir-elementos-de-madeira-6-conselhos-para-construir-estruturas-seguras-e-resistentes/5d8e6a24284dd144e9000143-como-unir-elementos-de-madeira-6-conselhos-para-construir-estruturas-seguras-e-resistentes-imagem?next\\_project=no](https://www.archdaily.com.br/br/927919/como-unir-elementos-de-madeira-6-conselhos-para-construir-estruturas-seguras-e-resistentes/5d8e6a24284dd144e9000143-como-unir-elementos-de-madeira-6-conselhos-para-construir-estruturas-seguras-e-resistentes-imagem?next_project=no)



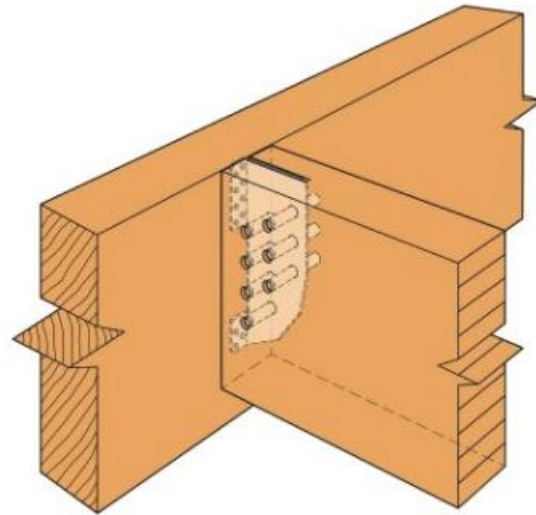
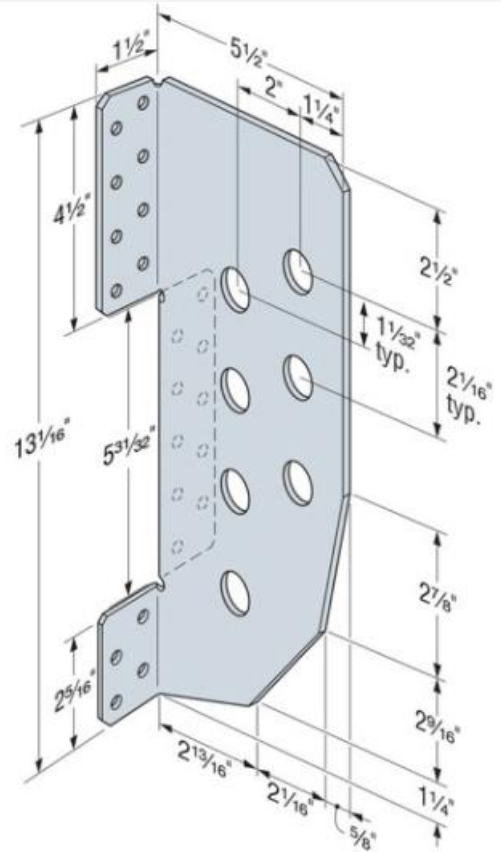

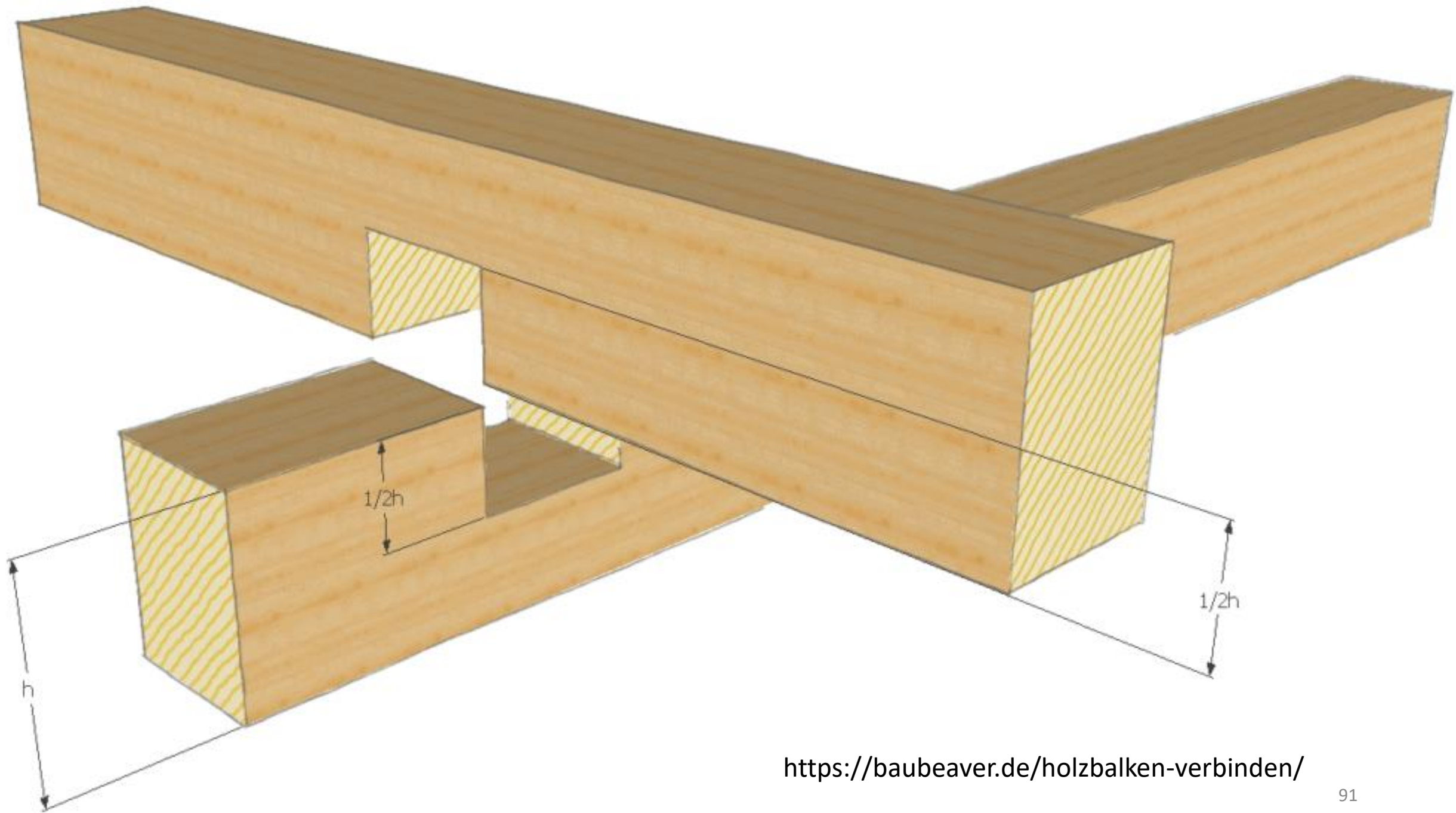

<https://baubeaver.de/holzbalken-verbinden/>

<https://baubeaver.de/wp-content/uploads/balken-verbinden-kreuzung-kreuzflachverbinder.png>

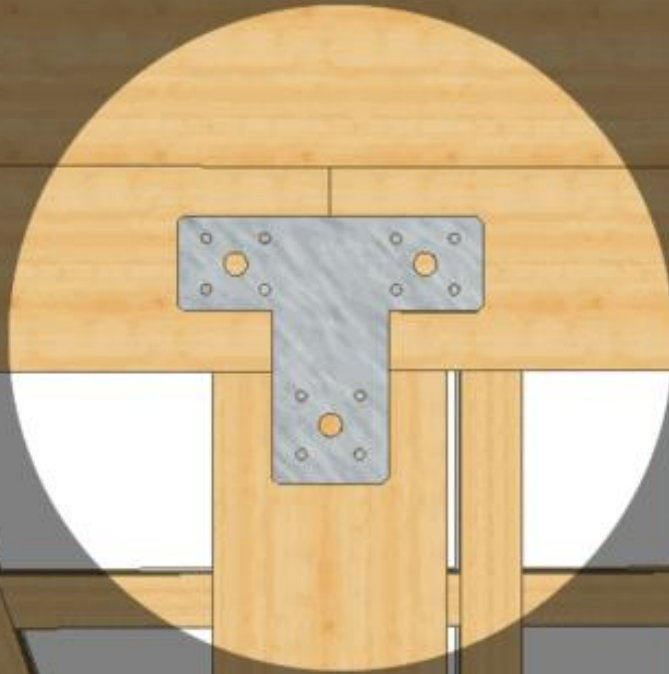



Ligações metálicas  
<https://www.topclamp.com/index.php?item=9252&g=10131>

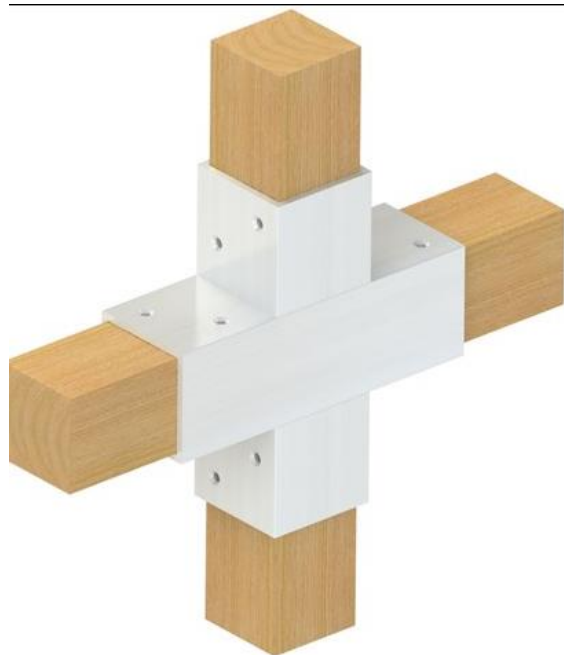
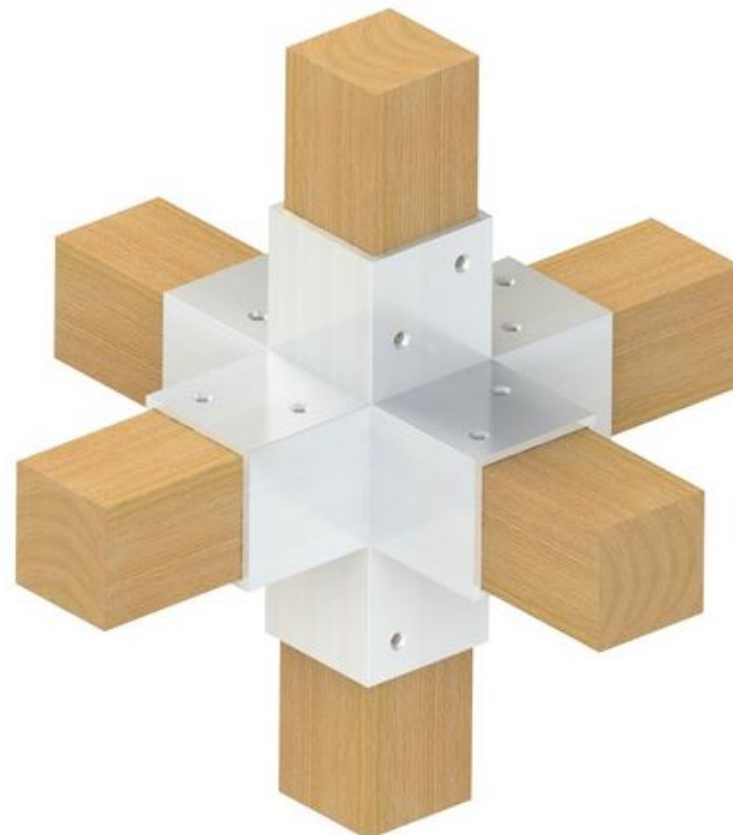



<https://www.ctpostandbeam.com/t-rex-connectors>





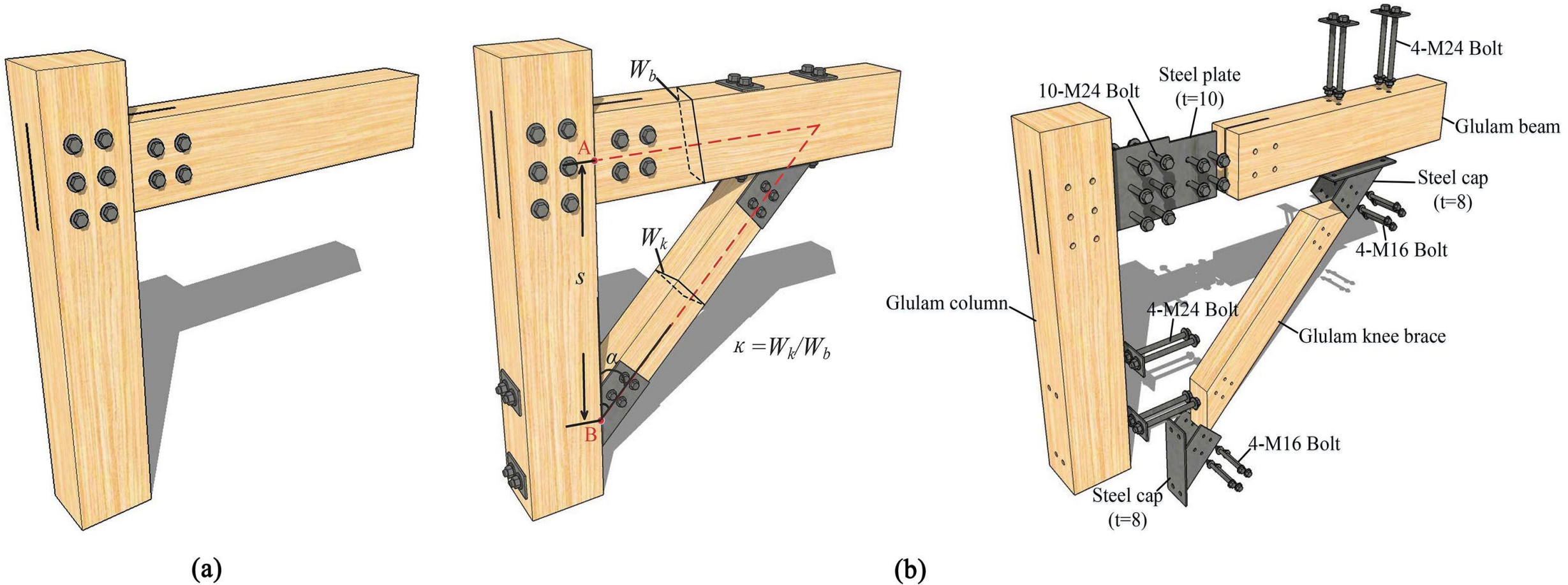

Minjuan, He at al. **Rotational behavior of bolted glulam beam-to-column connections with knee brace.**

Engineering Structures, vol. 207, 15 March 2020. Disponible em:

[https://www.sciencedirect.com/science/article/pii/S0141029619336387?casa\\_token=mtLo3-kf-uAAAAAA:F1vdB9uG7ZgyaWFuGOzYxKoMRCULRW6pLwM0x\\_xZcmorluQtR180zisS61BjFOQlcQXoRqYzVU](https://www.sciencedirect.com/science/article/pii/S0141029619336387?casa_token=mtLo3-kf-uAAAAAA:F1vdB9uG7ZgyaWFuGOzYxKoMRCULRW6pLwM0x_xZcmorluQtR180zisS61BjFOQlcQXoRqYzVU)



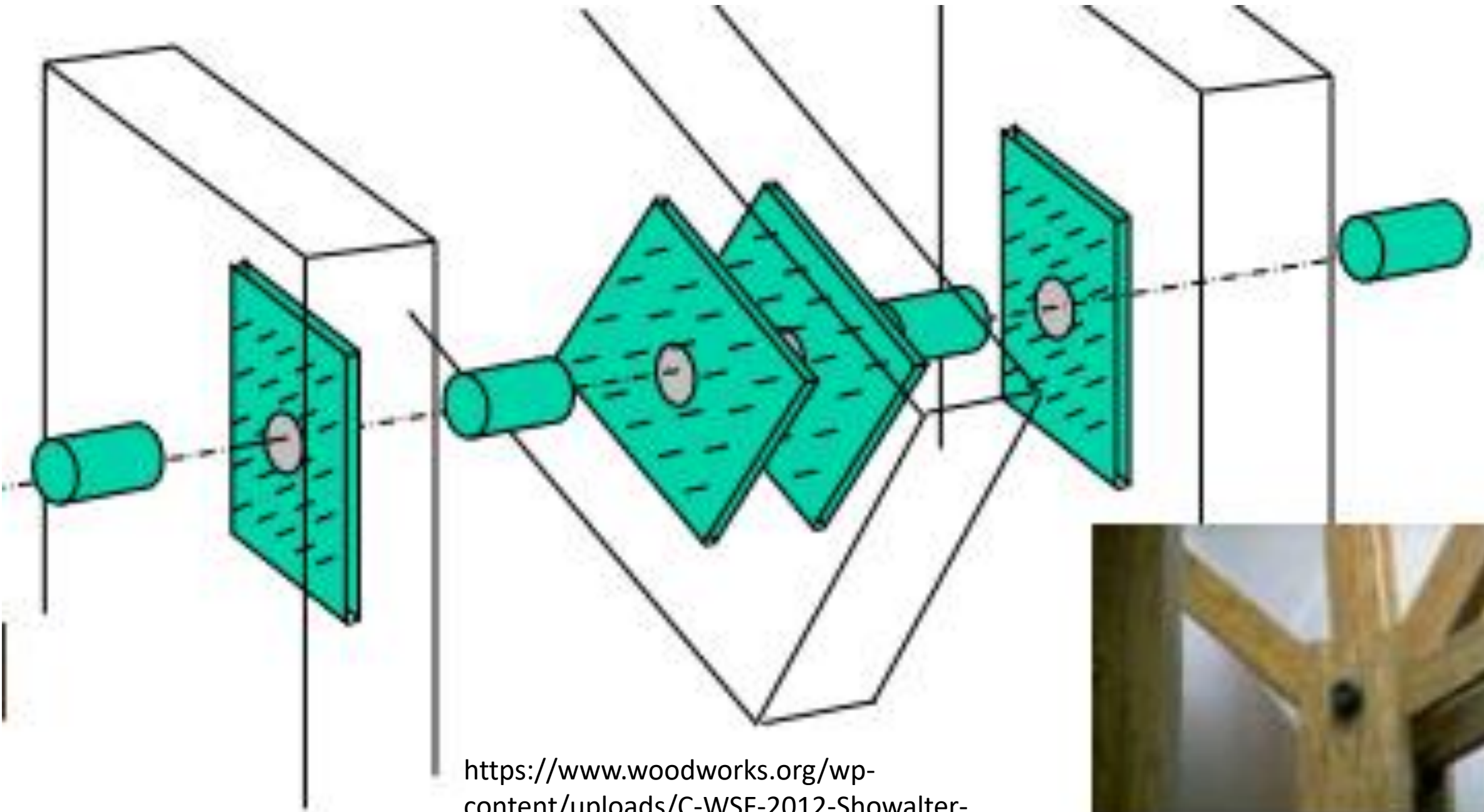

<https://www.woodworks.org/wp-content/uploads/C-WSF-2012-Showalter-Connections.pdf>

# Brackets

## BT (BracketT)

Design choices



**BTDD**  
Traditional bracket



**BTCV**  
Curved bracket



**BTTG**  
Tang bracket



**BTCR**  
Cross bracket

6

Timber Accents Design Guide



<https://cleverwoodprojects.org/>

<https://www.vermonttimberworks.com/our-work/heavytimber-construction/timberframe/>

<https://hbcrown.en.made-in-china.com/product/XNsEYtnVgHWu/China-Metal-Connecting-Brackets-Wood-Timber-Connector.html>



ARI TSUGI

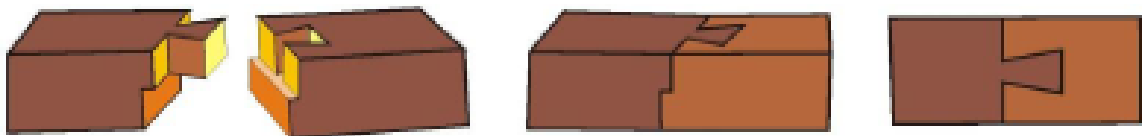

MECHIGAI  
HOZOTSUKI  
KAMA TSUGI

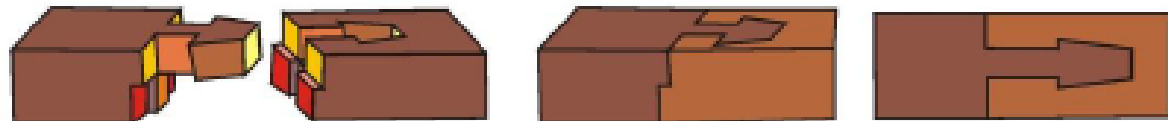

OKKAKE  
DAISEN  
TSUGI

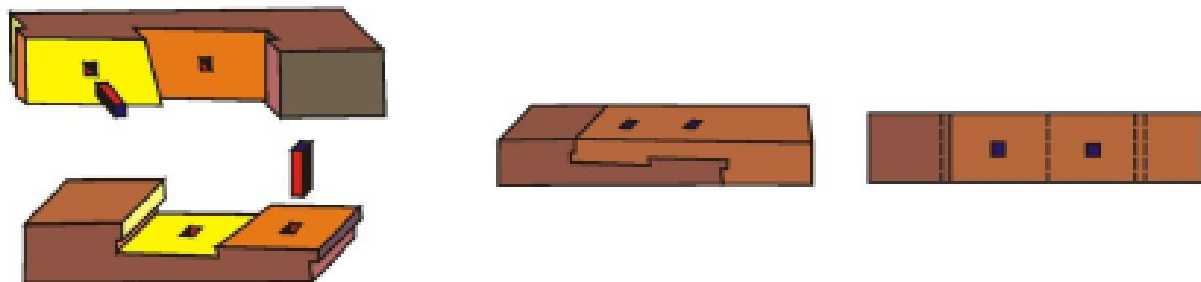

SHACHI  
TSUGI

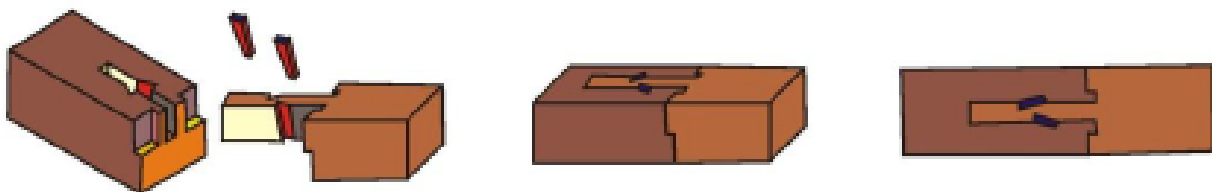

SUMIKIRI  
ISUKA  
TSUGI

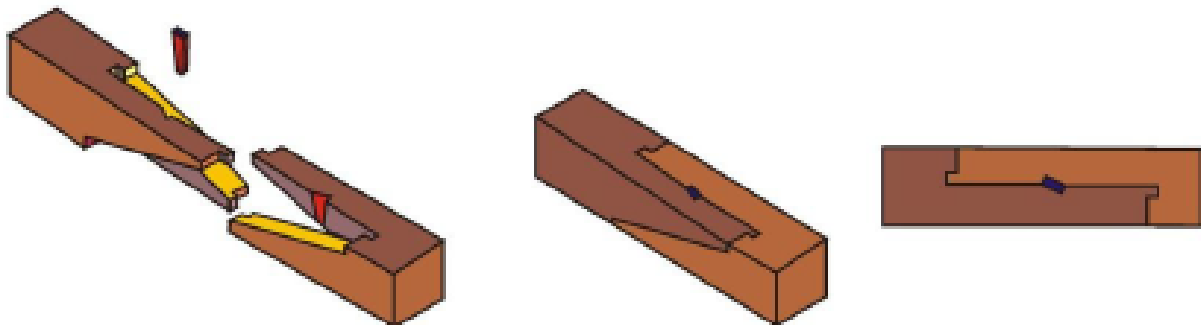

Numazawa, Camila Thiemy Dias -  
**Arquitetura japonesa  
no Pará** [dissertação] :

estudo de caso em edificações  
com técnica construtiva que  
favoreceu uma maior  
durabilidade da arquitetura em  
madeira no município de Tomé-  
Açu / Mestrado, UFSC,  
Florianópolis, SC, 2009

Disponível em:  
<https://repositorio.ufsc.br/xmlui/handle/123456789/92386>

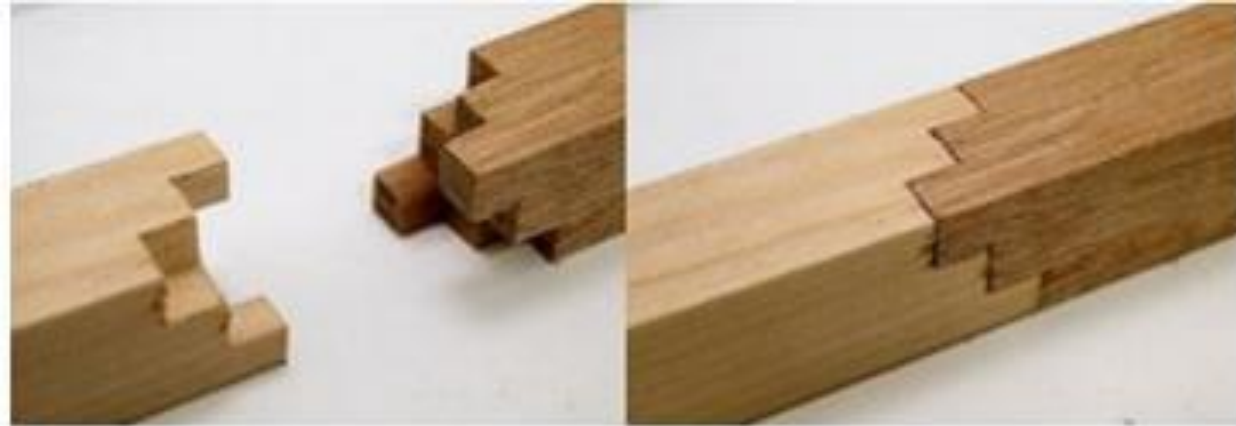

Encaixes japoneses para madeira -



<https://www.inovacaotecnologica.com.br/noticias/noticia.php?artigo=encaixes-madeira-japoneses-programa-gratuito&id=010150201022#.YT-ZEZ1KjIU>



Todas as imagens e textos possuem as fontes

no início de cada série.